





<b>Introduction .....</b>	<b>1.1</b>	Ride .....	3.16
<b>Introduction .....</b>	<b>1.1</b>	Theme .....	3.17
About This Manual .....	1.1	Brightness .....	3.18
<b>Identification Numbers .....</b>	<b>1.2</b>	Units .....	3.19
Identification Numbers .....	1.2	Language .....	3.19
<b>General Information .....</b>	<b>1.4</b>	Faults .....	3.20
		Time .....	3.20
		System .....	3.21
		Reset .....	3.22
<b>Safety Information .....</b>	<b>2.1</b>		
<b>General Safety Precautions .....</b>	<b>2.1</b>	<b>Starting and Operating .....</b>	<b>4.1</b>
General Safety Precautions .....	2.1	<b>General Operation .....</b>	<b>4.1</b>
Safe Riding Precautions .....	2.2	General Motorcycle Operation .....	4.1
Dash Battery Warning .....	2.3	Key Switch Positions .....	4.2
Software Modifications .....	2.3	Steering Lock .....	4.2
Location of Important Labels .....	2.4	Motorcycle Tip-Over Sensor .....	4.3
		Operating Your Motorcycle .....	4.4
		Powertrain System .....	4.5
<b>Controls and Components .....</b>	<b>3.1</b>		
<b>Controls and Components .....</b>	<b>3.1</b>	<b>Charging and Power Pack Information .....</b>	<b>5.1</b>
Motorcycle Controls .....	3.2	<b>Battery and Charging .....</b>	<b>5.1</b>
Left Combination Switch .....	3.4	Battery Guidelines .....	5.1
Right Combination Switch .....	3.5	Battery Charging .....	5.2
Dash Buttons .....	3.6	Battery Removal and Installation .....	5.4
Left Side View .....	3.8		
Right Side View .....	3.10		
Ride Modes .....	3.11		
Dash Overview .....	3.12		
Dash - Menu Interface .....	3.16		

<b>Maintaining Your Motorcycle</b> .....	<b>6.1</b>	<b>Technical Specifications</b> .....	<b>8.1</b>
<b>Maintaining Your Motorcycle</b> .....	<b>6.1</b>	<b>Specifications</b> .....	<b>8.1</b>
Scheduled Maintenance .....	6.1	Zero XE Technical Specifications .....	8.1
Component Fasteners .....	6.4		
<b>General Maintenance</b> .....	<b>6.9</b>	<b>Warranty and Customer Information</b> .....	<b>9.1</b>
Battery .....	6.9	<b>Limited Warranty Information</b> .....	<b>9.1</b>
Brakes .....	6.9	Who Is The Warrantor? .....	9.1
Front Suspension .....	6.11	Who Does This Limited Warranty Cover? .....	9.1
Rear Shock Adjustment .....	6.13	What Does This Limited Warranty Cover? .....	9.1
Wheels And Tires .....	6.16	What Is The Coverage Period Of This Limited Warranty? .....	9.2
Tire Inflation .....	6.16	What Is Not Covered By This Limited Warranty? .....	9.2
Drive Chain .....	6.17	What Other Limitations Or Disclaimers Apply To This Limited Warranty .....	9.4
Gear Oil Replace .....	6.20	What Are Your Responsibilities As A Customer? .....	9.5
Kickstand Inspection .....	6.20	What Will Zero Motorcycles Do Under This Limited Warranty? . 9.6	
Steering - Check/Adjustment .....	6.21	How Does This Limited Warranty Relate To State Law? .....	9.6
Headlight Adjustment .....	6.21	How Do You Obtain Service Under This Limited Warranty? .	9.7
Seat Removal .....	6.22	How Do I Transfer Ownership And The Limited Warranty .....	9.7
Cleaning .....	6.23		
		<b>Customer Information</b> .....	<b>9.8</b>
<b>Troubleshooting</b> .....	<b>7.1</b>	Customer Assistance .....	9.8
<b>Troubleshooting</b> .....	<b>7.1</b>	Reporting Safety Defects .....	9.8
Powertrain Overheating Logic .....	7.1		
Fault Codes .....	7.1	<b>Maintenance Record</b> .....	<b>10.1</b>
General Troubleshooting .....	7.7	<b>Maintenance Record</b> .....	<b>10.1</b>
		Service History .....	10.1

**First Responder Information - High Voltage  
Component Locations**



## About This Manual

The user should read the owner's manual carefully prior to using the product. The user must have a proper command of basic operation functions, operating techniques and maintenance awareness. Zero Motorcycles reserves the right to amend the manual at any time without a separate notice and does not assume any liabilities. No entities or individuals shall be allowed to reproduce any part of the manual without the Zero's written approval. We invite you to share your opinions on the design, manufacture or quality of the product. For recommendations and opinions, please contact Zero.

This manual details operating instructions, basic maintenance instructions and some troubleshooting information. For more detailed repairs, refer to the service manual. It is always recommended that you take your motorcycle to the dealer for the most qualified repairs.

The contents and images of this manual are for reference, only. Specifications are subject to the physical product.

For replacement parts, Zero recommends purchasing original genuine parts available via your Zero dealer.

## Cautionary Language

**NOTICE:** A "notice" calls attention to special instructions that require some level of emphasis.

**CAUTION:** A "caution" indicates potential danger that may cause damage to the motorcycle.

**WARNING:** A "warning" indicates there is potential injury hazard. Improper operation may cause personal injury and property safety.

## Identification Numbers

### Vehicle Identification Number (VIN)

The VIN is a 17-digit number stamped on the head tube of the frame. Do not alter or remove this number as it is the legal identifier for your motorcycle.

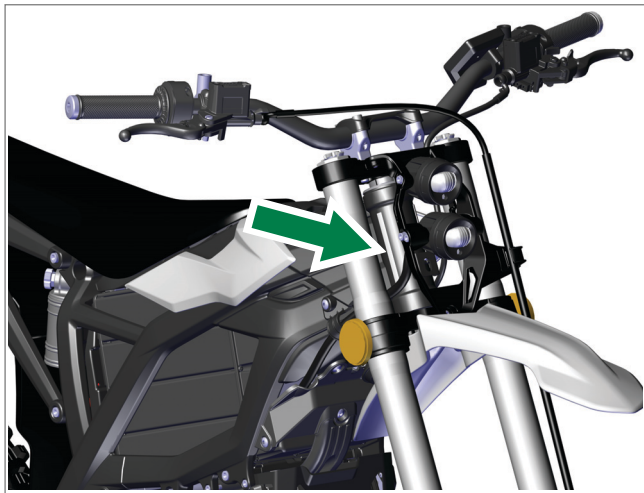

### Vehicle Nameplate

The vehicle nameplate is located on the frame just above the battery.



**Motor Serial Number**

The motor serial number is stamped on the right hand side of the motor housing.

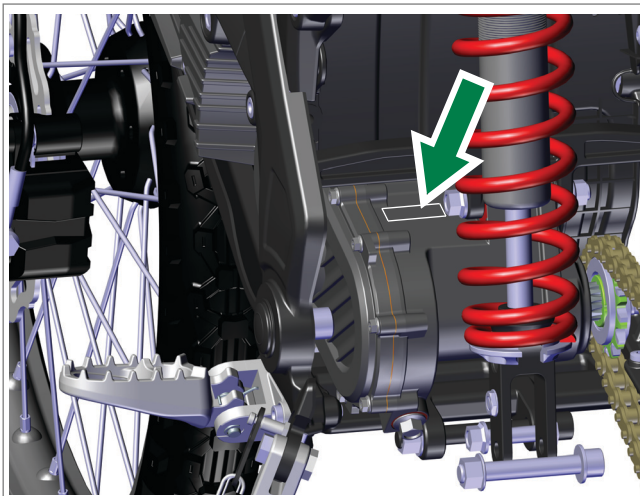

**Owner's Reference**

Fill in the corresponding number for future inquiry:

<b>VIN</b> _____
<b>Motor Number</b> _____

A series of horizontal dashed lines for writing notes.

## General Safety Precautions

### Operator Safety Dangers and Warnings

1. Strictly abide by traffic regulations and drive safely.
2. Persons without relevant motorcycle driving experience and a driver's license are prohibited from riding the motorcycle.
3. Do not lend the motorcycle to anyone that does not possess a driver's license.
4. Do not drive after drinking or taking medications.
5. This motorcycle is not for racing and racing competitions. If mechanical accidents and personal injuries are caused from such operation, the consequences are not the fault of Zero Motorcycles.
6. People with mental illness, history of mental illness, heart disease, hearing impaired and other restrictive disabilities are prohibited from driving the motorcycle.
7. Wear a helmet, dust-proof glasses, gloves and other protective equipment during driving.
8. Do not hang foreign objects onto the handlebar. Doing so will diminish safe operation.
9. Use the original charger provided with the motorcycle or a proper replacement charger as purchase through Zero.
10. Do not wear loose clothes, slippers, or other inappropriate outerwear. Doing so can create safety hazards.
11. Before unplugging the power plug, turn off the key switch first.

12. The battery must always be kept upright. When the motorcycle is not in use, it should be charged once a month to avoid damage to the battery caused by long-term power loss.

### Motorcycle Precautions

1. After unpacking, please check the attached accessories and various data according to the packing list.
2. This model can only carry the driver. The maximum payload of the motorcycle is 250 lb (114 kg).
3. Do not modify any part of the motorcycle. Doing so will affect the reliability, stability and comfort of the motorcycle.
4. Do not wash the motorcycle with high-pressure water. Doing so can cause damage to electronic components and circuits.

### Usage Suggestions

1. This manual is an essential component of the motorcycle. When the motorcycle is transferred to others for use, the owner's manual must stay with the motorcycle.
2. During the break-in period or warranty period, the user shall regularly go to the dealer for regular maintenance and adjustment as stipulated in ["Scheduled Maintenance"](#), on [page 6.1](#).

## Safe Riding Precautions

### Safety Guide

- Make sure you are legally qualified to drive an electric motorcycle.
- Read and follow all warnings, product descriptions, safety labeling and maintenance requirements in this manual.
- Drive only where permitted in accordance with local laws and regulations.

### Safe Riding Precautions

Make sure you are in good physical condition before riding.

- Always ride with both hands on the handlebars and your feet on the foot pegs during riding.
- Do not allow others to drive the motorcycle without proper guidance.
- Do not drive while fatigued or tired. Doing so can weaken your ability to make correct judgments and to drive safely.
- When raining or if the road is slippery, braking performance will be reduced. Use caution and drive slowly in slick conditions.
- Avoid excessive emergency braking, which will reduce the stability of the vehicle. If conditions permit, slow down before turning to lower the risk of slipping and losing control.

- Use caution when riding on low-friction roads such as gravel. On this type of surface, tires are more likely to slip and require a longer braking distance.
- If the battery emits an odor or smokes while riding, immediately turn off the power and park the motorcycle in a safe place outdoors, away from flammable materials. Contact your authorized dealer, immediately. Do not attempt to disassemble or modify the battery yourself.
- Be responsible for your riding behavior when operating the vehicle. Do not ride in a dangerous or uncivilized manner. Do not engage in riding behaviors that affect the safety of the public and yourself.

## Dash Battery Warning

<b>⚠ WARNING</b>	
<ul style="list-style-type: none"> <li>• <b>INGESTION HAZARD:</b> This product contains a button cell or coin battery.</li> <li>• <b>DEATH</b> or serious injury can occur if ingested.</li> <li>• A swallowed button cell or coin battery can cause <b>Internal Chemical Burns</b> in as little as <b>2 hours</b>.</li> <li>• <b>KEEP</b> new and used batteries <b>OUT OF REACH</b> of <b>CHILDREN</b>.</li> <li>• <b>Seek immediate medical attention</b> if a battery is suspected to be swallowed or inserted inside any part of the body.</li> </ul>	

**WARNING!** The nominal voltage of the battery is 3.0 V. Even used batteries may cause severe injury or death. Do not force discharge, recharge, disassemble, heat above (manufacturer's specified temperature rating) or incinerate. Doing so may result in injury due to venting, leakage, or explosion resulting in chemical burns. Call a local poison control center for treatment information.

**CAUTION:** The button cell battery within the dash is not serviceable. Do not attempt to open the dash and/or replace the battery.

## Software Modifications

**CAUTION:** Any customer modification to controller firmware or settings is strictly prohibited. Such modifications may compromise safety, vehicle performance, compliance, and void product warranty. To protect warranty coverage, customers must not alter, reprogram, or modify controller parameters under any circumstances.

## Location of Important Labels

The motorcycle could contain the following information for both North American and European models:

	<b>VEHICLE EMISSION CONTROL INFORMATION</b> <b>ZERO MOTORCYCLES, INC.</b>
ENGINE FAMILY:	THIS VEHICLE IS CERTIFIED TO OPERATE ON ELECTRICITY.
EXHAUST EMISSION CONTROL SYSTEM: BATTERY-ONLY ELECTRIC VEHICLE	
THIS VEHICLE CONFORMS TO U.S. EPA AIR EMISSIONS REGULATIONS APPLICABLE TO XXXX MODEL YEAR NEW HIGHWAY MOTORCYCLES.	
NO ADJUSTMENTS NECESSARY.	SEE OWNER'S MANUAL FOR DETAILS

**WARNING:** CLEAN FILLER CAP BEFORE REMOVING.  
USE ONLY DOT 4 FLUID FROM A SEALED CONTAINER.

 **WARNING!**

- Before unplugging the discharge connector, please turn off the vehicle's lock switch.
- In case of long time no use the battery pack, please unplug the discharge plug, and charge the battery every three months to have 30-60% SOC.
- Do not frequently allow the battery pack's SOC to drop below 20%, as this will reduce the using lifespan of the lithium battery.



MANUFACTURED BY/FABRIQUÉ PAR: ZERO MOTORCYCLES				DATE:
GVWR/PNBV: <input type="text"/>		COLD INFL. PRESS./		
GAWR/PNBE		TIRE/PNEU	RIM/JANTE	PRESS. DE GONFL À FROID
FR/AV	<input type="text"/>	<input type="text"/>	<input type="text"/>	<input type="text"/>
RR/AR	<input type="text"/>	<input type="text"/>	<input type="text"/>	<input type="text"/>

- A. VECI (Vehicle Emission Control Information) label
- B. Brake fluid warning

- C. Tire and loading information label
- D. Battery charging warning

This page intentionally left blank.

## Motorcycle Controls

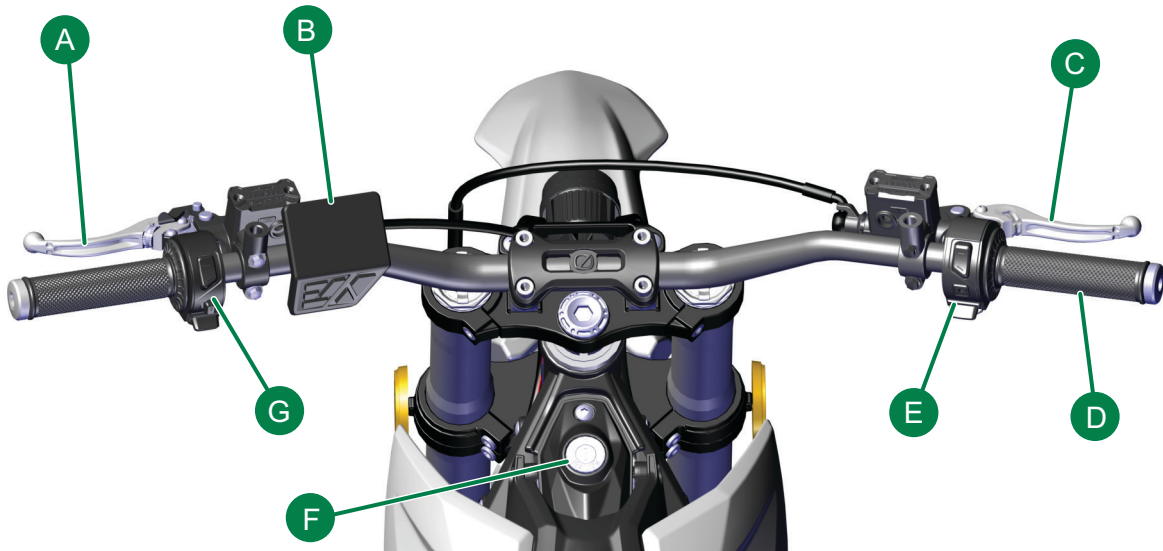

## A. Rear Brake Control

The rear brake lever controls the rear brake when the lever is squeezed. The brake light (if equipped) illuminates when the rear brake is applied.

## B. Dash

For Dash details see, [“Dash Buttons”, on page 3.6](#), [“Dash Overview”, on page 3.12](#), and [“Dash - Menu Interface”, on page 3.16](#).

## C. Front Brake Control

The front brake lever controls the front brakes when the lever is squeezed. The brake light (if equipped) will illuminate when the front brake is applied. When braking, release the throttle.

## D. Throttle Control

Twist the throttle in a counter-clockwise rotation to energize the motor and start the motorcycle in a forward direction. Release the throttle and it snaps back to the closed position, de-energizing the motor.

## E. Right Combination Switch

For description and operation, see [“Right Combination Switch”, on page 3.5](#).

## F. Key Switch

For description and operation, see [“Key Switch Positions”, on page 4.2](#) and [“Operating Your Motorcycle”, on page 4.4](#).

## G. Left Combination Switch

For description and operation, see [“Left Combination Switch”, on page 3.4](#).

## Left Combination Switch

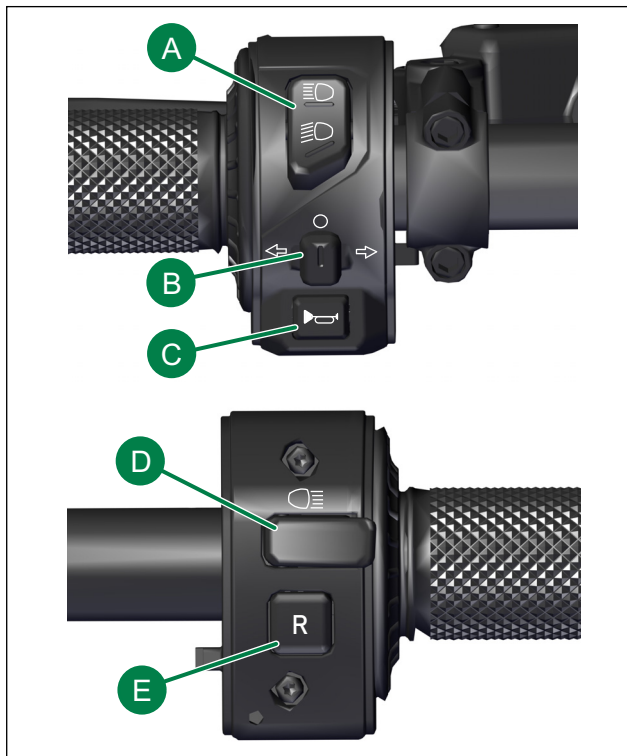

### A. Light Switch

Press the bottom of the light switch to enable the low-beam lamp. Press the top of the light switch to enable the high-beam lamp.

### B. Turn Signal Switch (Not Used)

When the turn signal switch is pushed in the left or right position, the corresponding front and rear turn signals flash. The corresponding turn signal indicator on the upper dash also illuminates.

Always signal your turns and other maneuvers as required by law. Unlike an automobile, the turn signals must always be canceled manually on the motorcycle. Move the switch back to the center to cancel.

### C. Horn Button

With the key in the ON position, press the horn button to sound the horn. Electric vehicles run quietly; the horn can be used to warn pedestrians or other motorists of your presence.

### D. Flash-to-Pass

When passing another vehicle, press this switch to illuminate the high-beam light to notify other vehicles your intention to pass. Release to turn off the high-beam light.

### E. Reverse Button

With the motorcycle stationary, press this button, then operate the throttle to reverse the motorcycle. When the button is released, the motorcycle will stop.

When in reverse, **Reverse** will be displayed on the dash.

*Note: If the throttle is held open, and the button is released, the motorcycle will stop. If the button is pressed again, while still opening the throttle, the motorcycle will reverse, once again.*

### Right Combination Switch

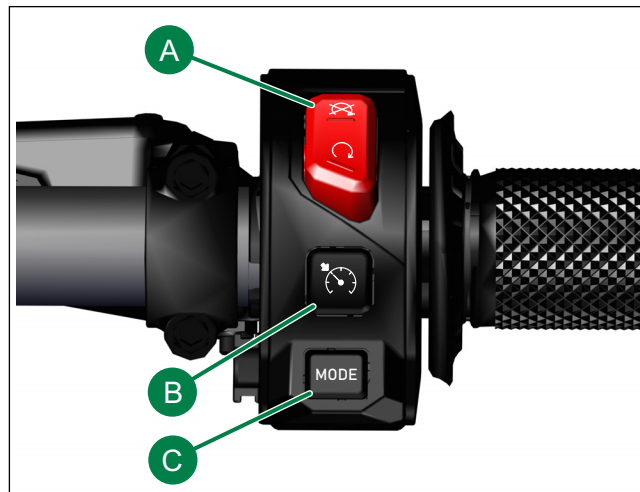

#### A. Kill Switch

Move the switch to the top position to disable the motor. Move the switch to the bottom position, to energize the powertrain for motorcycle travel. An indicator on the dash is used to alert the rider when the motor is disabled. See [“Dash Overview”](#), on page 3.12.

## B. Cruise Control

Press this button while riding to keep the motorcycle traveling at a constant speed without using the throttle control. The cruise control will cancel when braking, changing ride modes, pressing the kill switch or pressing the cruise control button again.

## C. MODE Button

With the motorcycle on (motor ready, throttle released), press this button to switch between ECO, STANDARD and SPORT modes. The dash will display the active mode. See [“Ride Modes”, on page 3.11.](#)

## Dash Buttons

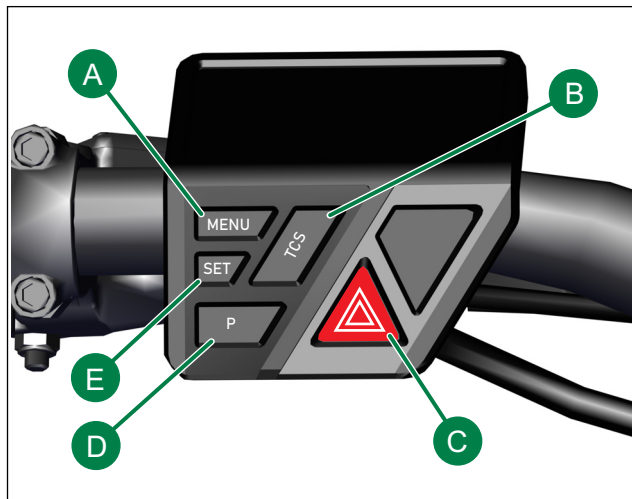

For details on the dash, see, [“Dash Overview”, on page 3.12,](#) and [“Dash - Menu Interface”, on page 3.16.](#)

## A. MENU Button

Short press: Enter the dash menu and select.

## **B. Traction Control System (TCS) Button**

Press the TCS button to toggle the traction control system on and off to limit wheel slippage during acceleration. The TC indicator light on the dash will illuminate whenever TCS is not turned on (or unavailable) or if a fault is present.

## **C. Hazard Switch (Not Used)**

Press this switch to activate the hazard lights. When on, the left and right turn signals flash at the same time. Press the switch again to turn the hazard lights off.

## **D. Park Button**

When the motorcycle is turned on, the Park indicator on the dash will be displayed. When the user presses this button, the indicator will turn off and the motorcycle can start to travel. When the button is pressed again, park will be enabled again and the motorcycle cannot travel.

## **E. SET Button**

Long press: dash function settings; Short press: dash function selection.

Left Side View

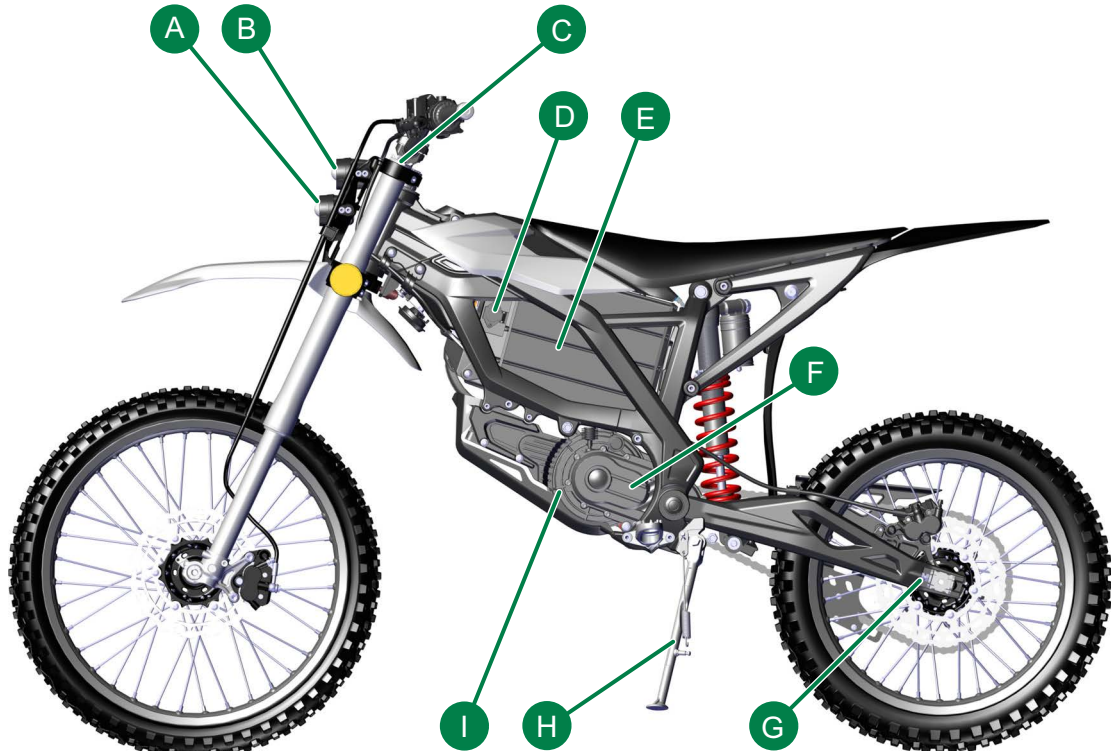

## A. High Beam Headlight

For headlight operation, see [“Left Combination Switch”](#), on page 3.4.

## B. Low Beam Headlight

For headlight operation, see [“Left Combination Switch”](#), on page 3.4.

## C. LH Fork Rebound Adjuster

For adjustment procedures, see [“Rebound Adjustment”](#), on page 6.12.

## D. Charging Port

For charging procedures, see [“Battery Guidelines”](#), on page 5.1.

## E. Battery

For more information, see [“Battery Guidelines”](#), on page 5.1.

## F. Gear Reduction

The gear reduction uses a set of gears to increase the torque of the motorcycle for quicker starts from stop.

## G. Left Axle Adjuster

The axle adjusters are used to adjust tension on the drive chain. For adjustment procedures, see [“Adjusting the Drive Chain”](#), on page 6.19.

## H. Kickstand

The kickstand swings out from the side and supports the motorcycle when fully deployed.

**CAUTION:** Park only on a flat firm surface, otherwise the motorcycle could fall over causing damage.

## I. Motor

The motor uses power from the battery to propel the motorcycle. The motor is activated using the kill switch. See [“Right Combination Switch”](#), on page 3.5.

Right Side View

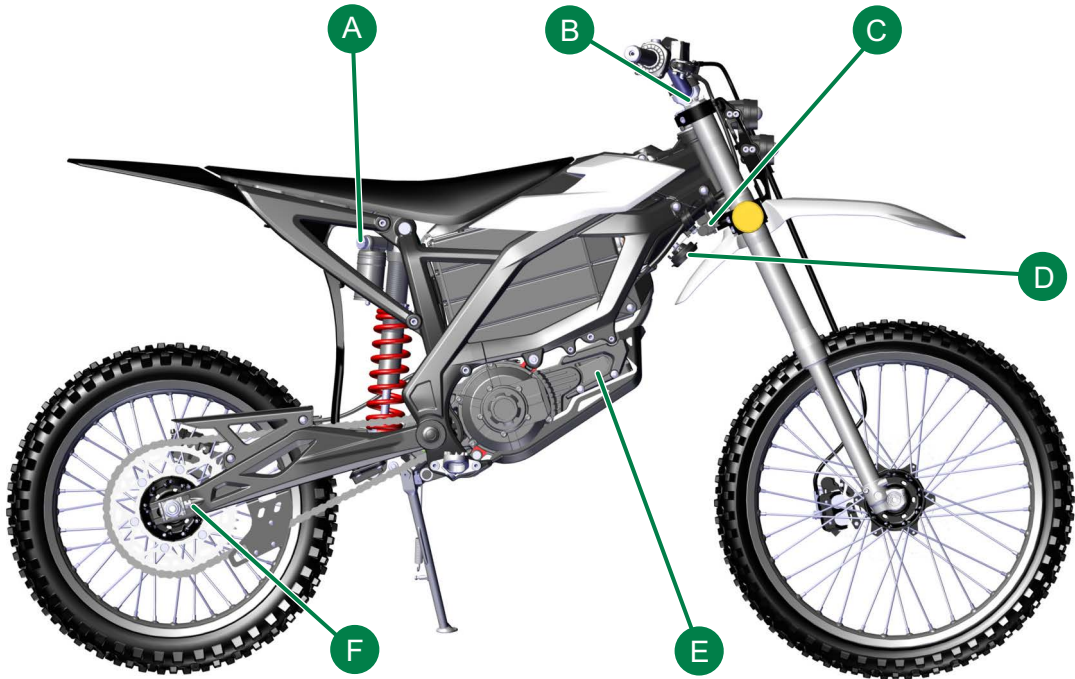

### A. Rear Suspension

The rear suspension keeps the rear wheel engaged with the ground during travel. The rear suspension is adjustable for rider comfort and preference. For adjustment details, see [“Rear Shock Adjustment”, on page 6.13.](#)

### B. Right Fork Rebound Adjuster

This adjuster controls rebound setting for the front suspension. For adjustment details, see [“Rebound Adjustment”, on page 6.12.](#)

### C. Steering Lock

For description and operation, see [“Steering Lock”, on page 4.2](#)

### D. Horn

Pressing the horn button on the left combination switch sounds the horn. See [“Left Combination Switch”, on page 3.4.](#)

### E. Motor Controller

Controls the flow of battery power to the motor according to the action of the throttle and riding conditions.

### F. Right Axle Adjuster

The axle adjusters are used to adjust tension on the drive chain. For adjustment procedures, see [“Adjusting the Drive Chain”, on page 6.19.](#)

## Ride Modes



This motorcycle can switch between three modes, with the default being the STANDARD mode. Repeatedly, press the MODE button to cycle through each mode. To set, the motorcycle must be on, the kill switch in the run position and the throttle released.

*Note: The motorcycle can be in motion when changing modes, as long as the throttle is released.*

- ECO: Softer power and acceleration, suitable for new riders.
- STANDARD: Moderate power and acceleration, suitable for use after becoming familiar with motorcycle handling.
- SPORT: Strong power suitable for non-paved roads such as forest roads. It is recommended that users use this mode only after they are familiar with the motorcycle.

## Dash Overview

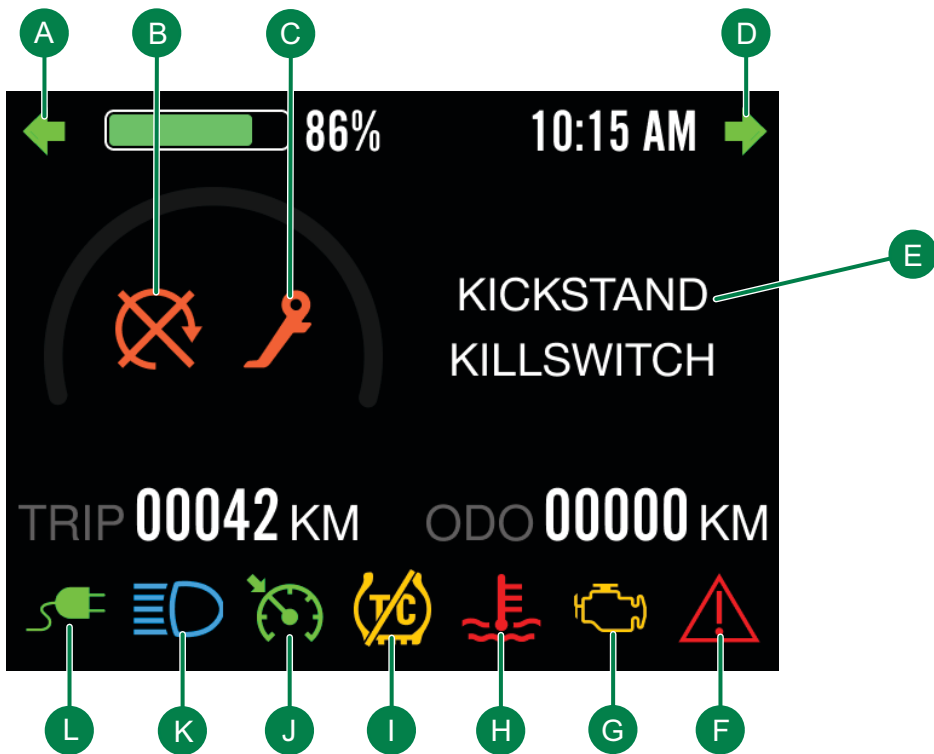

**A. Left Turn Indicator (Not Used)**

The indicator will flash while the left turn signal (if equipped) is in use.

**B. Kill Switch Indicator**

Displays when the motor is disabled using the kill switch. When the kill switch is enabled, the indicator will turn off. See [“Right Combination Switch”, on page 3.5](#)

**C. Kickstand Indicator**

Displays when the kickstand is fully deployed.

**D. Right Turn Indicator (Not Used)**

The indicator will flash while the right turn signal (if equipped) is in use.

**E. Kickstand/Killswitch Textual Indicator**

KICKSTAND and/or KILLSWITCH will display when their corresponding indicators (B & C) are displayed.

**F. Tip-Over Indicator**

Displays when the motorcycle has initiated motorcycle tilt protection mode. See [“Motorcycle Tip-Over Sensor”, on page 4.3.](#)

**G. Malfunction Indicator**

Displays if a motorcycle fault is active. See [“Fault Codes”, on page 7.1.](#)

**H. Temperature Indicator**

The indicator will light if the battery, motor or controller approach or exceed normal operating temperature limits, which could be restricting performance or charging.

*Note: When the temperature indicator is illuminated, the malfunction indicator may be illuminated, as well. This is considered normal behavior. During times when the temperature rises to the set limit, the warning system acts as a normal response and is not indicative of a failure. See [“Powertrain Overheating Logic”, on page 7.1.](#)*

**I. Traction Control System (TCS) Indicator**

This icon (with strike through) is displayed on the dash when TCS is off. With TCS on, the icon (no strike through) is displayed when a TCS event is activated while riding. See [“Dash Buttons”, on page 3.6.](#)

**J. Cruise Control Indicator**

Displays while cruise control is active.

**K. High Beam Indicator**

Displays while the high beam light is in use.

**L. Charging Indicator**

With the power on, this indicator will light when the battery is charging.

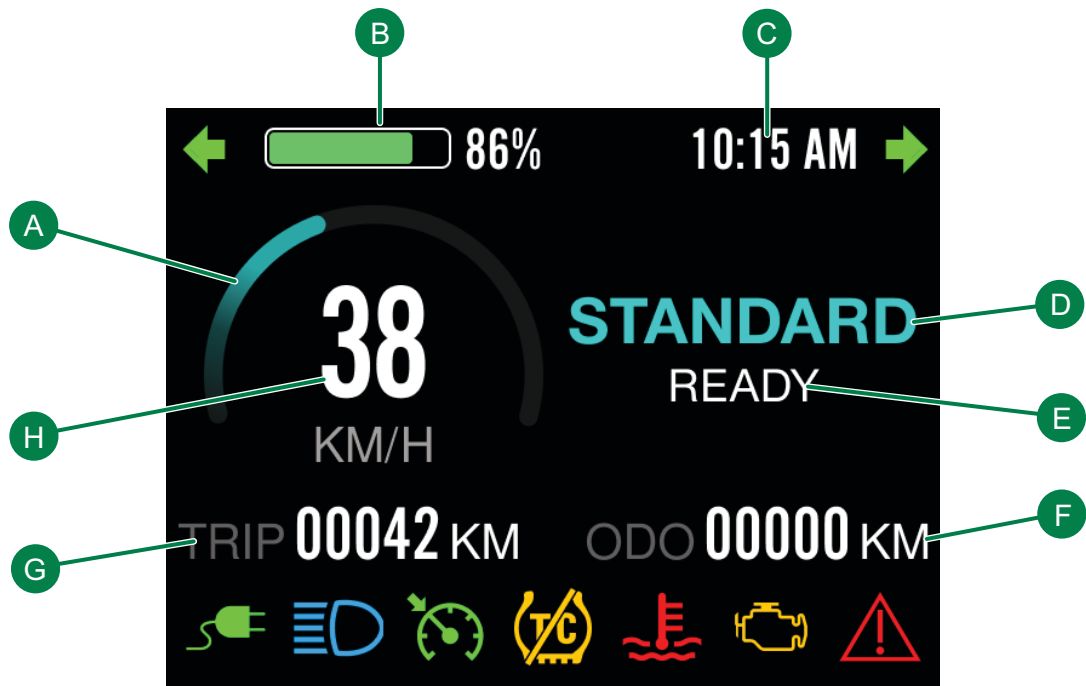

**A. Motor Speed**

Displays the current motor speed. Only displays when the motor is enabled using the kill switch.

**B. Battery Indicator**

Displays the current State of Charge (SOC) of the battery.

**C. Clock**

Displays the current time.

**D. Ride Mode**

Displays the current ride mode as selected on the right combination switch. See [“Ride Modes”, on page 3.11](#).

Park will be displayed when the motorcycle is powered on or when the park button is activated. See [“Dash Buttons”, on page 3.6](#).

**E. Ready Indicator**

Ready will display when the kill switch is in the bottom position to enable travel. See [“Right Combination Switch”, on page 3.5](#).

**F. Odometer**

Displays the total mileage of the motorcycle.

**G. Trip Odometer**

Displays the current trip mileage. This mileage can be reset at each trip.

To reset: Long press the SET button. When the trip odometer starts to blink, short press SET to reset to 0.

**H. Speedometer**

Displays the current motorcycle speed. The speedometer is only displayed when the kickstand is up and the kill switch is in the bottom position to enable travel. See [“Right Combination Switch”, on page 3.5](#).

## Dash - Menu Interface

1. With the motorcycle in park mode, short press the **MENU** button to enter the menu interface of the dash to access the following:
  - RIDE
  - THEME
  - BRIGHTNESS
  - UNITS
  - LANGUAGE
  - FAULTS
  - TIME
  - SYSTEM
  - RESET
2. Refer to the following sections for instructions on changing the settings.

## Ride

The RIDE screen allows the user to change the following:

- Tip Over Assist - This feature cuts off throttle signal to the motor in the event of a motorcycle tip-over event. If this occurs, the tip over indicator light will be displayed on the dash. See [“Dash Overview”](#), on page 3.12 for the location of the indicator. See [“Motorcycle Tip-Over Sensor”](#), on page 4.3 for more details and instructions on resetting after a tip-over.
- Uphill Assist - This feature prevents the motorcycle from rolling backwards or forwards while on an incline.
- Regen Level - This is meant to control the rate of current feedback or rate of brake regeneration on the motorcycle with 1 being the lowest setting and 3 the highest. When set to the highest, the bike slows down more rapidly when coasting (throttle released) due to higher brake regeneration.

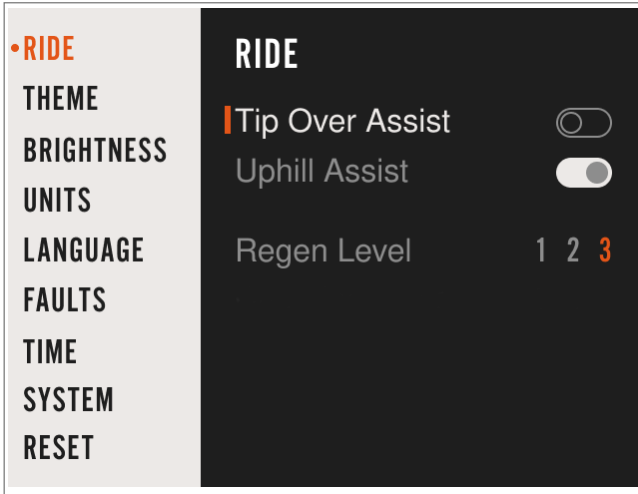

1. Short press the **MENU** button to enter the Menu interface, then long press the **SET** button to enter the RIDE screen.
2. Short press the **SET** button to cycle through the RIDE functions.
3. Long press the **SET** button to set the function, then short press the **MENU** button to confirm and exit

## Theme

The Theme screen allows the user to change the display to either a light or a dark background theme.

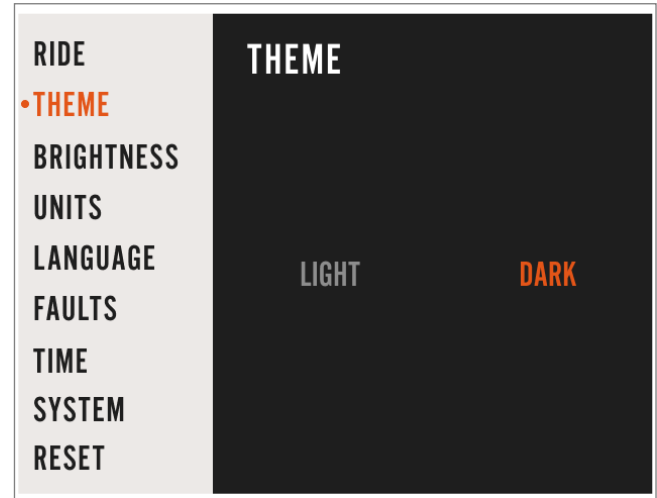

1. Short press the **MENU** button to enter the Menu interface. Short press the **SET** button to cycle through the menu items, then long press the **SET** button to enter the THEME screen.
2. Short press the **SET** button to switch themes, then short press the **MENU** button to confirm and exit.

## Brightness

The BRIGHTNESS screen allows the user to change the display to adjust the display brightness for optimal visibility per current lighting conditions. There are five levels with 1 being the darkest and 5 being the brightest.



1. Short press the **MENU** button to enter the Menu interface. Short press the **SET** button to cycle through the menu items, then long press the **SET** button to enter the BRIGHTNESS screen.

2. Short press the **SET** button to cycle through the brightness levels. Short press the **MENU** button to set the desired level and exit.

## Units

The UNITS screen allows the user to toggle the display between miles and kilometers.

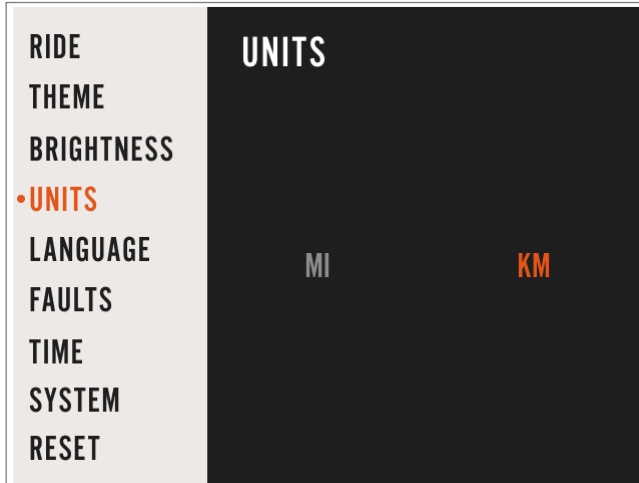

1. Short press the **MENU** button to enter the Menu interface.  
Short press the **SET** button to cycle through the menu items, then long press the **SET** button to enter the UNITS screen.
2. Short press the **SET** button to switch between miles and kilometers, then short press the **MENU** button to confirm and exit.

## Language

The LANGUAGE screen allows the user to change the display to the desired display language.



1. Short press the **MENU** button to enter the Menu interface.  
Short press the **SET** button to cycle through the menu items, then long press the **SET** button to enter the LANGUAGE screen.
2. Short press the **SET** button to toggle through the languages, then short press the **MENU** button to confirm and exit.

## Faults

The Faults screen allows the user to view any active faults.

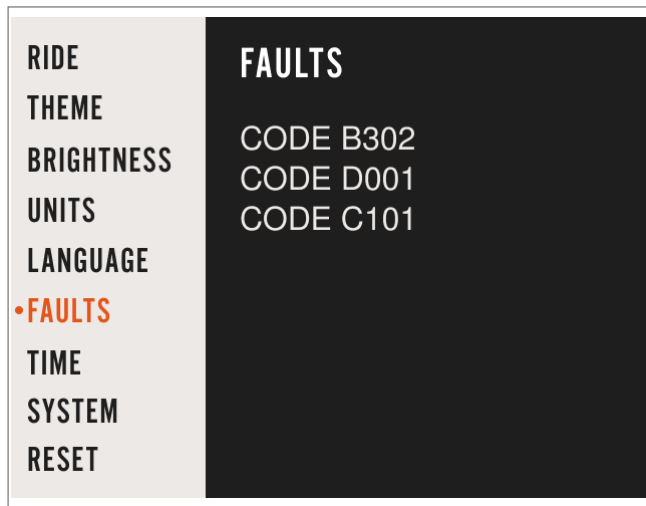

1. Short press the **MENU** button to enter the Menu interface.  
Short press the **SET** button to cycle through the menu items, then long press the **SET** button to enter the FAULTS screen. See [“Fault Codes”, on page 7.1](#) for a description of the available fault codes.
2. Short press the **MENU** button to exit.

## Time

The Time screen allows the user to set the current time and to select a 12 hour or 24 hour format.

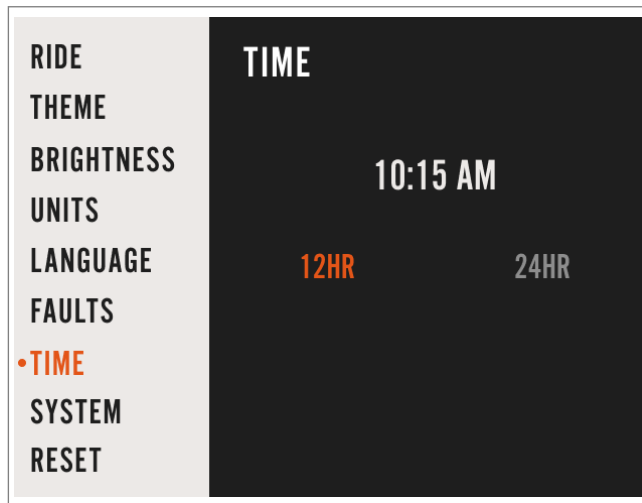

1. Short press the **MENU** button to enter the Menu interface.  
Short press the **SET** button to cycle through the menu items, then long press the **SET** button to enter the TIME screen.
2. Short press the **SET** button to switch between 12h or 24h modes.

- Long press the **SET** button to enter hour adjustment mode. Short press the **SET** button to adjust the hour as needed. After setting the hour, long press the **SET** button again to enter minute adjustment mode. Short press the **SET** button to adjust the minutes as needed.

*Note: When the 12h format is selected, cycle through the hours to achieve the correct AM or PM setting.*

- Once the time is set, short press the **MENU** button to complete the time setting and exit.

## System

The SYSTEM screen allows the user to view the current dash software and firmware versions.

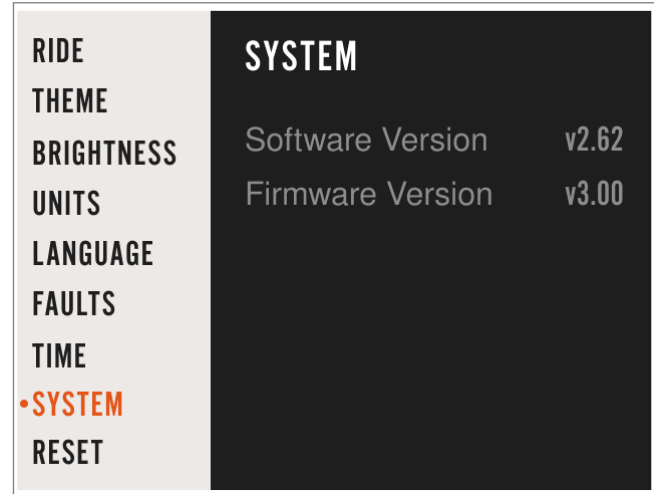

- Short press the **MENU** button to enter the Menu interface. Short press the **SET** button to cycle through the menu items, then long press the **SET** button to enter the SYSTEM screen.
- Short press the **MENU** button to exit.

## Reset

The RESET screen allows the user to reset the display settings to the factory default settings.

*Note: Resetting will also cause the trip odometer to blink for reset. Short press the SET button to zero the trip odometer.*

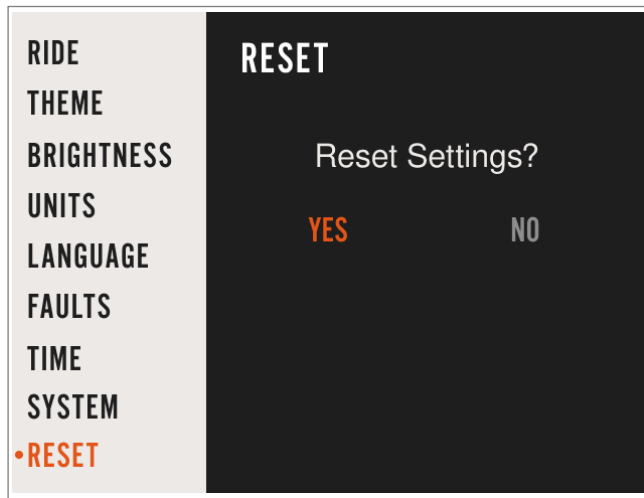

1. Short press the **MENU** button to enter the Menu interface.  
Short press the **SET** button to cycle through the menu items,  
then long press the **SET** button to enter the RESET screen.

2. Short press the **SET** button to toggle between YES or NO.
3. Long press the **SET** button for confirmation.  
If YES is selected, the dash will automatically return to the  
main interface after setting.

## General Motorcycle Operation

This section describes several items you should examine before operation.

### Pre-Ride Inspection

Before operating your Zero Motorcycle, check the following to make sure the motorcycle is secure and intact:

- Ensure that the headlamp and signal lamps are working properly.
- Check whether the handlebar turns freely. If the handlebar does not rotate freely, and the steering column has axial movement, looseness or jamming, adjust the steering column adjusting nut. See [“Steering - Check/Adjustment”, on page 6.21.](#)
- Check if the handlebar needs to be tightened. Make adjustments if necessary, refer to [“Component Fasteners”, on page 6.4.](#)
- Check the battery pack to ensure that the power displayed on the battery pack indicator (either on the battery or on the dash) is sufficient to operate the motorcycle. The battery pack is displayed for reference, only. Driving style and environmental factors will effect the range.
- Check drive chain tension. See [“Drive Chain”, on page 6.17.](#)
- Check the brakes. See [“Brakes”, on page 6.9.](#)
- With the key switch off, rotate the throttle and release it. Verify that the throttle rotates freely and returns to the default position.
- Check the wheels, tires, and tire pressure. See [“Wheels And Tires”, on page 6.16.](#)
- Check if the power-off function of the kickstand is normal. See [“Dash Overview”, on page 3.12.](#)
- Check the compression rebound of the front and rear shock absorbers. Inspect for oil leakage or foreign matter affecting the operation of the shock absorbers. See [“Front Suspension”, on page 6.11](#) and [“Rear Shock Adjustment”, on page 6.13.](#)
- Check the surface of each front inner fork tube. Ensure the fork tubes are lubricated as outlined in [“Post-Ride Maintenance”, on page 6.13.](#)

*Note: The quiet operation of the powertrain allows other noises to be noticeable during operation. The front suspension has a break-in period of 500 miles (800 km). During this period, it is normal to hear some squeaking in the front suspension. Proper lubrication will mitigate this during the break-in period.*

## Key Switch Positions

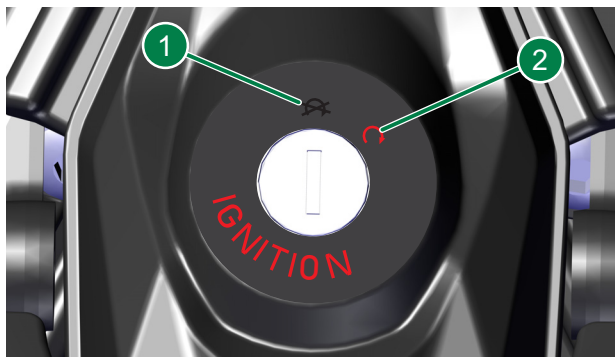

This is a two -position switch that is located on the console in front of the seat. The switch positions are as follows:

- Off (1) - All power and travel is disabled.
- On (2) - Power to the motorcycle is enabled for accessory use and travel.

Remove the key from the motorcycle when parked to prevent theft.

## Steering Lock

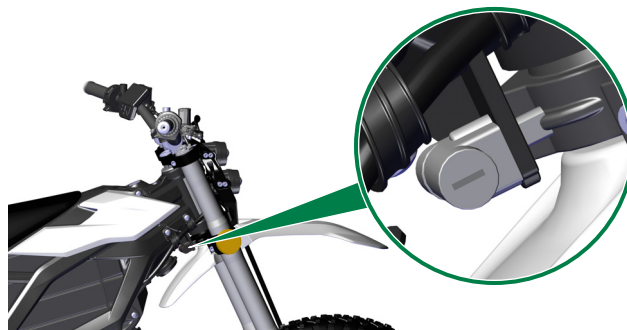

1. Turn the handlebar to the left so that the steering lock tongue aligns with the limiting hole.
2. Insert the key and turn clockwise to lock the handlebar. When ready to ride, insert the key and turn counter-clockwise to unlock the steering.

## Motorcycle Tip-Over Sensor

Your motorcycle has a tip-over sensor that will disable the motorcycle's drive mode in the event it is activated. If your motorcycle's tip-over sensor is activated:

- The motorcycle drive mode will be disabled while tipped-over.
- The motorcycle can't be driven or charged while in a tipped-over state.
- Stand the motorcycle upright and perform one full key cycle (turn the key to the OFF position, wait for the display to go blank and then turn the key back to the ON position) to reset the sensor.

## Operating Your Motorcycle

This section describes how to safely operate your motorcycle.

### Starting

1. Turn the key switch to the ON position. See “[Key Switch Positions](#)”, on page 4.2.
2. Raise the kickstand and move the kill switch to the ON position. **PARK** will appear on the dash panel.
3. Hold the front and rear brake levers or press the P (park) button on the dash panel to release the motorcycle from park mode.
4. Use the MODE button to select the desired mode for riding.
5. After confirming that the surrounding environment meets the conditions for riding, slowly twist the throttle to start and ride the motorcycle.

### Braking

Simultaneously, squeeze the right brake lever to enable the front brakes and the left lever to enable the rear brakes. Release the throttle when braking.

**WARNING!** Avoid excessive braking, especially in a turn, to prevent skidding and/or rolling over.

**WARNING!** Water and silt will affect braking performance, increase braking distance and cause danger. Tap the brakes to restore brake performance.

**WARNING!** In situations such as long and steep slopes and downhills, repeated braking will cause severe overheating of the brakes and affect braking performance. To ensure safety, operate the front and rear brakes simultaneously and use the brakes intermittently for deceleration.

### Stopping Your Motorcycle

To stop your motorcycle:

1. Return the throttle grip to its neutral position and press the top of the kill switch to shut off power to the motor.
2. Lower the kickstand, and slowly lean the motorcycle to the left until its weight is resting on the kickstand.
3. Turn the key switch to the off position and remove.

## Powertrain System

The motorcycle's electric drive system is a powertrain system that is mainly composed of a battery, motor and a controller, which can communicate and interactively control and provide driving force to the rear wheel.



The powertrain system is a 74 Volt, high-voltage system. If required, it must be repaired or replaced by Zero-trained technician. It is strictly prohibited for users to disassemble and/or modify any the powertrain system components and associated wiring.

**WARNING:** Improper handling or tampering can lead to electric shock and/or burning.

During operation of the motorcycle, the motor emits a buzzing sound. The buzzing is the sound of high-speed magnetic field vibration, that is, the sound generated by the normal magnetic moment effect. This is a normal phenomenon.

The controller is a precision component and is sensitive to external impact. Use caution when operating to prevent damage to the controller's electronic components.

Due to its high voltage electronic components, incorrect wiring and incorrect screw torque can lead to controller damage or power system burnout.

If a powertrain fault is active on the dash, bring the motorcycle to a Zero dealer for diagnosis and repair.



## Battery Guidelines

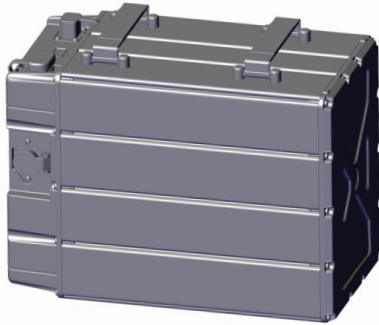

**WARNING:** If the battery pack has been dropped or damaged, the waterproof structure of the battery pack may be damaged and the seal affected. To avoid danger in this instance, contact your Zero Motorcycle dealer. The battery pack is a waterproof battery, but it has high voltage and precision circuits inside. It is strictly prohibited to allow water intrusion and moisture into the battery. Only Zero-trained technicians can service a battery.

1. Due to certain logistical issues, battery power may be insufficient, or the battery power display may be different from the actual power. The motorcycle may have problems such as short battery life, weak power, and inaccurate power display. Fully charge the battery before using.

2. The recommended temperature range for lithium batteries is 5° F to 113° F (-15° C to 45° C) with best performance between 50° F to 86° F (10° C to 30° C). If the ambient temperature is too low or too high, it will affect the performance and service life of the battery. Do not operate the motorcycle while temperatures are beyond the allowable range. Do not charge the battery below 32° F (0° C).
3. When the ambient temperature is too low or too high, battery performance will be affected, as stated above. As temperatures move into the normal operating range, battery performance will automatically recover.
4. Avoid deep discharge of the battery as this will diminish the service life of the battery. Charge the battery when the power indicator is low. The controller on this motorcycle is equipped with an under-voltage protection device. When the charge level is too low, the power drop and under-voltage protection are normal. It will automatically recover after charging.
5. When not in use for long periods of time, charge the battery pack to 40% - 60% and store it in a relatively dry environment at 68° F to 77° F (20° C to 25° C). Charge the battery pack once a month to ensure that the battery pack is in the range of 40% - 60%. Charge the battery pack once a year to 100%, discharge it to less than 10%, and then maintain it regularly according to the above maintenance methods to avoid affecting the performance and life of the battery pack and causing permanent damage.

6. Do not wash the battery pack directly with a pressure washer when washing the motorcycle. High-pressure washing can cause water intrusion into the battery pack causing internal damage. If water intrusion is suspected, do not charge or operate the motorcycle. Doing so may cause safety accidents such as fire, combustion and explosion of the battery pack.

### Battery Charging Charging Guidelines

Check and confirm the following before charging:

1. Whether the electrical outlet being used is consistent with the input voltage/ampere range of the charger.
2. Whether the socket load power of the AC power grid can meet the power requirements of the charger (above 840W is recommended)
  - The battery management system prohibits charging when the internal temperature is high in order to preserve the life of the battery. The maximum allowable charging temperature inside the battery pack is 113° F (45 °C). If it exceeds this temperature, it will not be able to charge. After riding, the battery management system may delay charging if the battery temperature is too hot. Charging will resume when the battery cools to within range.

**CAUTION:** Do not use other methods to rapidly heat or cool the battery pack. The battery must be allowed to gradually warm and cool with the ambient temperature.

- The battery management system prohibits charging when the internal battery temperature is at or below 32° F (0° C). Charging will resume when the battery warms to within range. If the battery is too cold to charge, allow the battery to warm naturally without the aid of any heating device.

- Charge the battery pack only with a dedicated charger matched to the original motorcycle or specified by Zero. It is strictly forbidden to use other chargers or accessories to charge this motorcycle. Non-approved equipment may cause battery failure or damage, and can even cause fires.
- Charge the motorcycle in a dry, well-ventilated environment away from combustibles. Do not charge in the rain.
- Disconnect the charger before operating the motorcycle.

**WARNING:** If the battery is dropped or damaged during a collision, the housing can become damaged. If the housing is damaged a peculiar smell may be observed during charging and discharging. Excessive heat may also be observed if the housing is damaged. If either occur, stop charging and disconnect the power supply immediately. Do not use the motorcycle. Contact your Zero Motorcycle dealer.

**WARNING:** If the battery pack begins smoking or catches fire, it is necessary to use a (Class D) fire extinguisher to extinguish the fire. It is also advised to contact the fire department.

## Charging

NOTE: The battery can be charged while installed in the motorcycle or while removed. To remove, see ["Battery Removal and Installation"](#), on page 5.4.

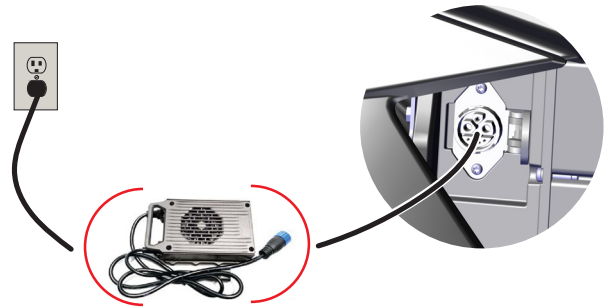

1. Connect the charger output plug to the battery charging port socket.
2. Connect the charger input plug to the power supply.
3. Make sure the charging indicator on the battery indicates the battery is charging.
4. After the battery is fully charged (solid green light on charger), disconnect the charger from the electrical outlet, first. Then, unplug the charger from the battery charging port on the battery.

## Battery Removal and Installation

### Removal

1. Remove the seat. Refer to “[Seat Removal](#)”, on page 6.22.

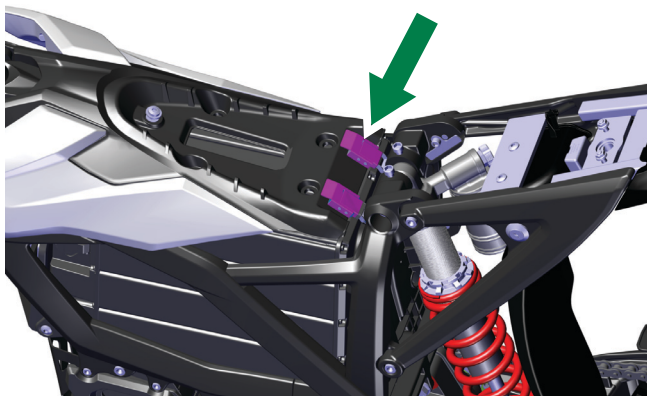

2. Unlatch the battery compartment and rotate the door upward to gain access to the battery.

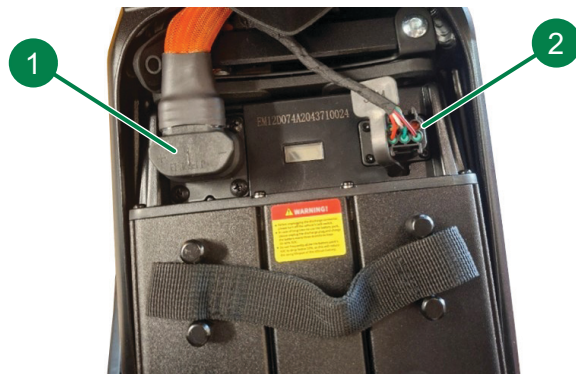

3. Disconnect battery communications connector (2).
4. Disconnect discharge connector (1).
5. Vertically lift the battery out of the compartment.

**WARNING:** Install the battery terminal cover on the battery while the battery is unplugged to avoid any accidental contact.

### Installation

1. Installation is the reverse of the removal procedure with the exception of the battery connectors. Install discharge connector (1) first, then install the communications connector (2).

## **Scheduled Maintenance**

During normal wear and tear, various parts may loosen and become mechanically worn to varying degrees. In addition to the daily routine maintenance of the vehicle, the motorcycle must also be maintained in a planned and correct manner, so as to keep it in the best running state, prolong its service life, reduce maintenance costs and achieve the purpose of safe riding.

For this reason, a detailed maintenance cycle schedule has been made for the vehicle, which contains the maintenance items, maintenance cycle, maintenance frequency and the need to pay attention to matters. If you do not have enough experience skills and tools, please go to the nearest dealer for maintenance. The user shall be responsible for the damage of parts or riding accidents caused by wrong maintenance, disassembly and installation.

## **Maintenance Schedule**

The scheduled maintenance must be performed in accordance with this chart to keep the Zero Motorcycle in top running condition. The initial maintenance is vitally important and must not be neglected. Where time and mileage are listed, follow the interval that occurs first.

# Maintaining Your Motorcycle

#	Item	Routine	Every ride	Initial 60 mi (100 km)	Every 300 mi (500 km)	Every 1,250 mi (2000 km)	Every 3,100 mi (5000 km)	Every 6, 200 mi (10K km) or 12 months
1	Tires	Check/adjust air pressure. Check tread depth and replace when necessary.	√					
2	Various hardware	Check hardware torque. See <a href="#">“Component Fasteners”</a> , on <a href="#">page 6.4</a> . Replace as necessary.				√		
3	Brake operation	Check operation and for damage. Adjust as necessary. Monitor pad wear and replace when necessary.	√					
4	Brake fluid	Check and fill as necessary.	√					
		Replace.						√
5	Gear Oil	Replace at initial 1800 mi (3000 km). Then, replace every 4 months or 4300 mi (7000 km) (whichever comes first).						
6	Sprockets	Inspect for wear.				√		
7	Drive chain	Check tension and adjust. Inspect for wear.		√	√			
		Replace.					√	
8	Wheel and spokes	Check for damage. Check spoke tightness. Tighten if necessary.	√					

#	Item	Routine	Every ride	Initial 60 mi (100 km)	Every 300 mi (500 km)	Every 1,250 mi (2000 km)	Every 3,100 mi (5000 km)	Every 6, 200 mi (10K km) or 12 months
9	Front/rear suspension	Check operation and check for leakage.	√					
		Replace as necessary.						√
10	Battery	Inspect for damage.	√					
11	Wiring harnesses	Inspect and check that harnesses are properly secured along the bike.				√		
11	Headlights	Check operation.	√					
12	Bike tip-over protection	Check operation.				√		
13	All bearings: wheel, steering, suspension linkage, swingarm	Check bearings for smooth operation. Replace as necessary.				√		

## Component Fasteners

Periodically check and tighten the following fasteners on your motorcycle.

### Torque Table 1

Refer to the illustration in [“Left Side Of Motorcycle”, on page 6.5](#)

ITEM	DESCRIPTION	TORQUE
1	Front brake rotor bolts	7 ± 1.5 lb-ft (10 ± 2 Nm)
2	Front axle pinch bolts	7 ± 1.5 lb-ft (10 ± 2 Nm)
3	Front caliper bolts	22 ± 1.5 lb-ft (30 ± 2 Nm)
4	Tail frame to frame bolts	20 ± 2 lb-ft (27.5 ± 2.5 Nm)
5	Rear brake rotor bolts	7 ± 1.5 lb-ft (10 ± 2 Nm)
6	Kickstand bolt	20 ± 2 lb-ft (27.5 ± 2.5 Nm)
	Kickstand nut	9 ± 2 lb-ft (12.5 ± 2.5 Nm)
7	Swingarm to frame	81 ± 7 lb-ft (110 ± 10 Nm)
8	Left and right foot pegs	20 ± 2 lb-ft (27.5 ± 2.5 Nm)

9	Front axle	20 ± 2 lb-ft (27.5 ± 2.5 Nm)
10	Lower triple clamp pinch bolts	12 ± 1.5 lb-ft (16 ± 2 Nm)

Left Side Of Motorcycle

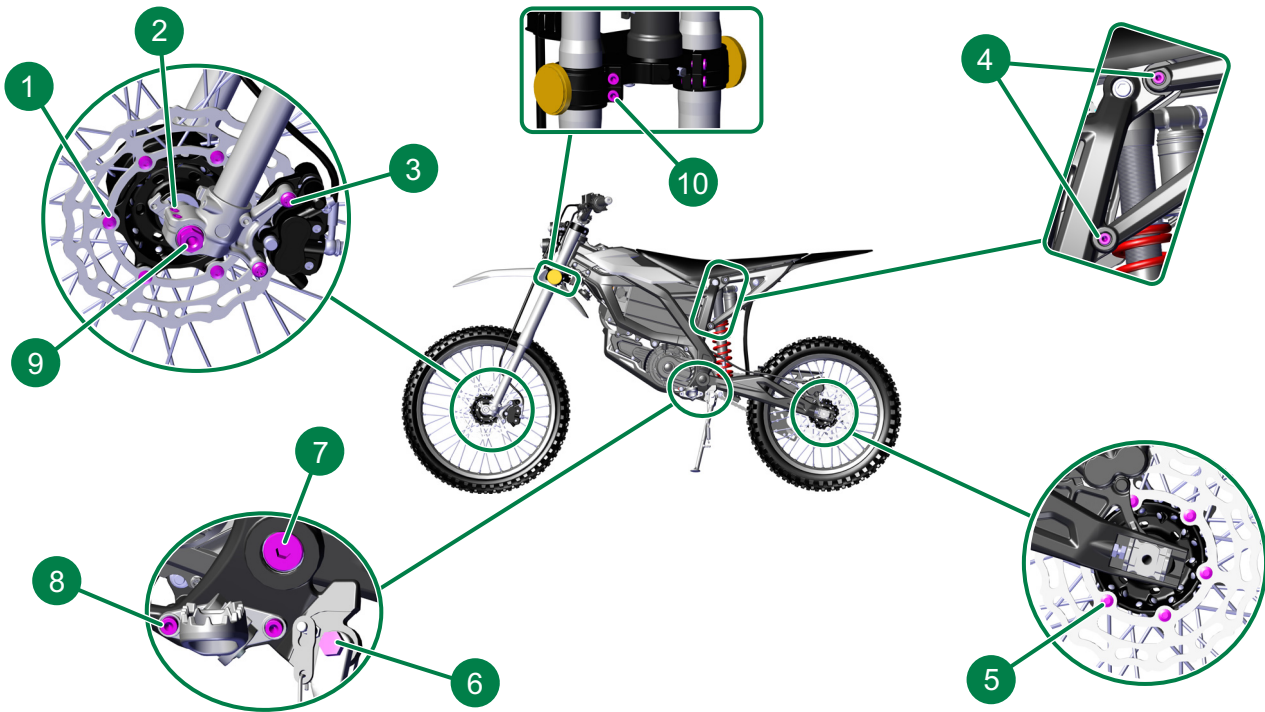

Refer to "Torque Table 1", on page 6.4

# Maintaining Your Motorcycle

## Torque Table 2

Refer to the illustration "Right Side Of Motorcycle", on page 6.7

ITEM	DESCRIPTION	TORQUE
1	Rear shock top mount	55 ± 4 lb-ft (75 ± 5 Nm)
2	Wishbone linkage to swingarm	55 ± 4 lb-ft (75 ± 5 Nm)
3	Dogbone to wishbone linkage	55 ± 4 lb-ft (75 ± 5 Nm)
4	Steering shaft bolt	55 ± 4 lb-ft (75 ± 5 Nm)
5	Handlebar clamp bolts	20 ± 2 lb-ft (27.5 ± 2.5 Nm)
6	Steering adjustment nut	See Service Manual.
7	Upper triple clamp pinch bolts	14 ± 1 lb-ft (19 ± 1 Nm)
8	Front battery support	20 ± 2 lb-ft (27.5 ± 2.5 Nm)
9	Front motor mount	44 ± 4 lb-ft (60 ± 5 Nm)
10	Rear battery support	20 ± 2 lb-ft (27.5 ± 2.5 Nm)
11	Rear (lower) motor mount	22 ± 1.5 lb-ft (30 ± 2 Nm)

12	Rear (upper) motor mount	44 ± 4 lb-ft (60 ± 5 Nm)
13	Rear axle	81 ± 7 lb-ft (110 ± 10 Nm)
14	Rear sprocket screws	22 ± 1.5 lb-ft (30 ± 2 Nm)
15	Dogbone to frame mount	55 ± 4 lb-ft (75 ± 5 Nm)
16	Rear shock lower mount	37 ± 4 lb-ft (50 ± 5 Nm)

Right Side Of Motorcycle

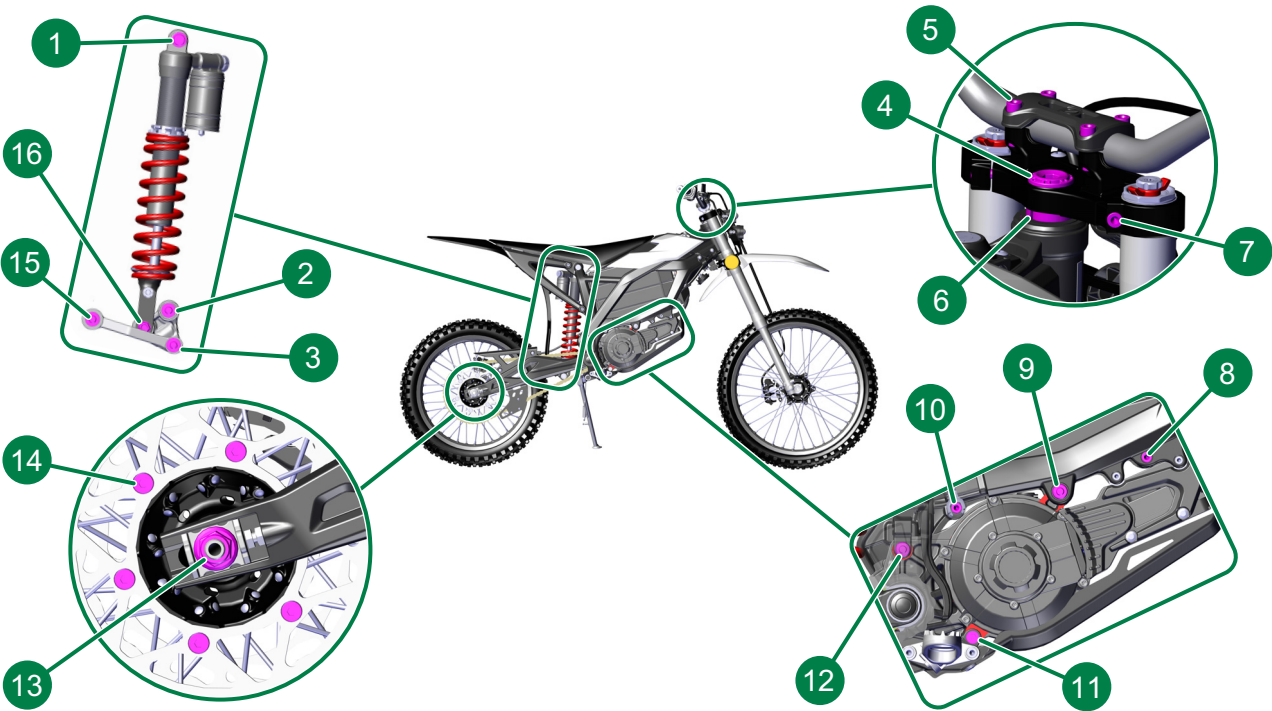

Refer to "Torque Table 2", on page 6.6.

## Standard Torque Values

Use the following table for hardware that is not specified in the previous table.

Hardware Size	TORQUE
M5 bolts/nuts	$4 \pm 1$ lb-ft ( $5 \pm 1$ Nm)
M6 bolts/nuts	$7 \pm 1.5$ lb-ft ( $10 \pm 2$ Nm)
M8 bolts/nuts	$22 \pm 1.5$ lb-ft ( $30 \pm 2$ Nm)
M10 bolts/nuts	$30 \pm 4$ lb-ft ( $40 \pm 5$ Nm)
M5 screws	$4 \pm 1$ lb-ft ( $5 \pm 1$ Nm)
M6 screws	$6.5 \pm 1.5$ lb-ft ( $9 \pm 2$ Nm)

## Battery

1. The battery is a lithium battery system, which requires periodic charging to ensure battery activity. Refer to “[Battery Guidelines](#)”, on page 5.1 for charging and storing guidelines.
2. Keep the battery in a moderate storage climate away from extreme low or high temperature environments. Do not store in direct sunlight. Keep it in a clean, dry, ventilated room with moisture-proof, dust-proof, shockproof, and corrosion-resistant measures. Avoid contact with corrosive substances and keep away from sources of fire and heat. See “[Battery Guidelines](#)”, on page 5.1 for storage details.
3. The battery internals are not serviceable and only an authorized service agent is qualified to open the battery case. Do not attempt to remove any outer covers from the battery.
4. Dispose of the battery according to local laws and regulations. It is encouraged that the battery be recycled rather than disposed of in landfills.
5. Contact Zero at [support@zeromotorcycles.com](mailto:support@zeromotorcycles.com) or locate a recycling center in your area.

## Brakes

The braking system is extremely important component to ensure the personal safety of riders and is the core component of motorcycle safety. The brake system must be checked and maintained regularly.

**WARNING:** Brake fluid is highly toxic - keep containers sealed and out of the reach of children. If accidental consumption of fluid is suspected, seek medical attention immediately.

**WARNING:** If the fluid comes into contact with the skin or eyes, rinse immediately with plenty of water.

**WARNING:** Do not ride the motorcycle if the brake fluid is below the lower third section of the sight glass. Brake fluid **MUST** be added to the reservoir before riding.

**WARNING:** If the brake lever travel is unusually long, the feel is spongy or if there is any significant loss of brake fluid contact your Zero Motorcycles Dealer. Riding under such conditions could result in extended stopping distances or complete brake failure.

**CAUTION:** Only use new fluid from an airtight container. Fluid from open containers or fluid previously bled from the system will have absorbed moisture, which will adversely affect performance, and must not be used.

**CAUTION:** Brake fluid will damage plastic or painted surfaces. Soak up any spillage with an absorbent cloth immediately and wash the area with a mixture of car soap and water.

# General Maintenance

The fluid level in the reservoirs may drop slightly during normal use, as a result of brake pad wear, but should not be below the lower third section of the sight glass.

## Brake Inspection

Check the brake system before each use and confirm that the system is working properly.



1. Observe the brake fluid level from the sight glass on each brake lever assembly. Ensure the brake fluid is above the bottom 1/3 of the sight glass. Add fluid as necessary. See [“Adding Brake Fluid”, on page 6.11.](#)

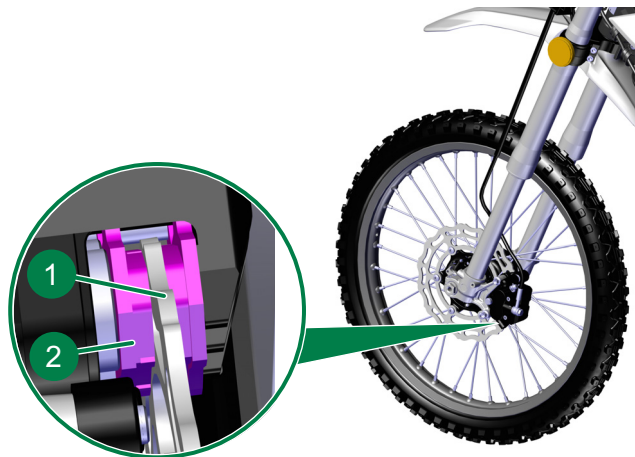

2. Check the wear of friction plate (2) and brake disc (1). If the thickness of friction plate is less than the maintenance limit value of 2.5 mm and the thickness of brake disc is less than the limit value of 2.0 mm, replace the friction plate and brake disc.

## Adding Brake Fluid

Inspect the level of the front brake fluid through the sight glass. If the fluid level is visibly below the lower 1/3 of the sight glass, brake fluid must be added. Clean any dirt or debris from the cover before opening the reservoir.



1. Remove the two screws securing the cover onto the reservoir.
2. Add new DOT 4 brake fluid so that the fluid is above the lower 1/3 of the sight glass.
3. Inspect the cover seal, ensuring that it is free of any wear or damage and that it is positioned correctly.
4. Install the cover and tighten the screws to 5 lb in (0.56 Nm).

## Front Suspension

This motorcycle features front forks with adjustable preload and rebound damping. The preload adjuster on the left fork allows you to set how much the suspension compresses under the weight of the bike and rider, which affects ride height and how much travel is available. The rebound adjuster on the right fork controls how quickly the suspension returns to its extended position after being compressed.

### Inspection

1. Check the appearance of the front forks for damage, cracks, and oil leakage. Repair as necessary.
2. Hold the front brake firmly to lock the front wheel. Compress the forks by pressing down on the handlebars several times and observe how the fork returns to full extension. Adjust the rebound adjuster dial to achieve smooth and controlled motion when returning to full extension.
3. Make adjustments as necessary for rider preference. Refer to:
  - [“Rebound Adjustment”, on page 6.12](#)
  - [“Compression Adjustment”, on page 6.12](#)

## Rebound Adjustment



- Rotate in the + direction to increase the damping. This slows down rebound speed.
- Rotate in the - direction to decrease the damping. This speeds up rebound speed.

## Compression Adjustment



- Rotate in the + direction to increase compression. This makes the shock absorption harder.
- Rotate in the - direction to decrease compression. This makes the shock absorption softer.

## Post-Ride Maintenance

1. Clean the surface of each fork immediately after each ride and promptly remove any sediment attached to the surface of the fork tubes.

**CAUTION:** When cleaning, do not direct pressurized water or air upwards towards the lip of the fork dust seal (as shown in the figure) Doing so can allow contaminants to enter the chamber causing jamming, wear and oil leakage.



2. After cleaning, use a soft cotton cloth and neutral cleaning agent to clean the surface of the fork tube.

**CAUTION:** Do not use solvents that are easily soluble or corrosive to avoid damage to the dust seal.

3. Apply a thin layer of a stanchion lubricant or other silicon-based lubricant on the surface of the fork tube after cleaning to keep the fork surface lubricated.

## Rear Shock Adjustment

A shock has two main actions: compression when the shock gets loaded, and rebound when the shock returns back to full length. Compression damping is the adjustment that determines how fast or slow the suspension compresses. Rebound damping is the adjustment that determines how fast or slow the suspension rebounds.

Obtaining the correct rear spring preload is critical for proper handling. The spring preload must be set to match the weight of the rider.

### Inspection

1. Check the appearance of the rear shock absorber for damage, cracks, or oil leakage. Repair as necessary.
2. Sit on the motorcycle to check the preload setting. Adjust as necessary. See [“Preload Adjustment”, on page 6.14](#)
3. Press down on the seat several times while observing compression (resistance to compression) and rebound (speed of return from compressed position). Check whether the rebound is smooth. Adjust as necessary. See [“Rebound Adjustment”, on page 6.15](#) and [“Compression Adjustment”, on page 6.14](#).

## Preload Adjustment

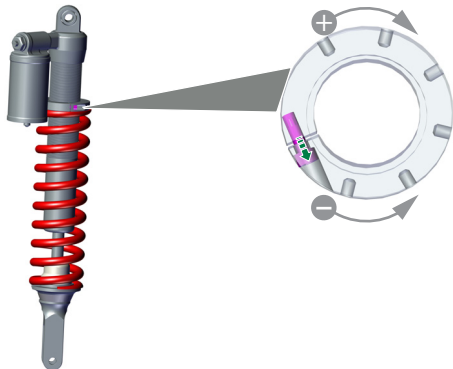

Obtaining the correct rear spring preload (sag) is critical for proper handling. The preload must be set to match the weight of the rider. Loosen the pinch bolt to adjust. (Torque: 4 lb-ft (5 Nm))

- Rotate in the + direction (clockwise) to increase preload.
- Rotate in the - direction (counter-clockwise) to decrease preload.

## Compression Adjustment

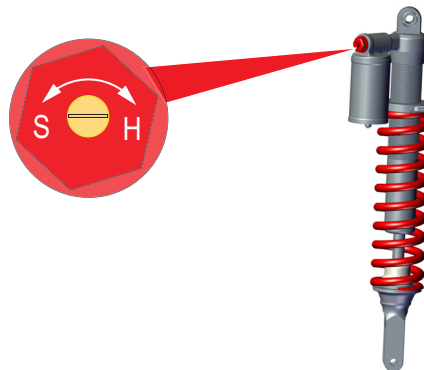

Compression that is set too hard will pack-up (feel harsh over consecutive bumps), while compression that is set too soft causes the shock to bottom out harshly. If the shock is bottoming out, turn the adjuster one click at a time until the bottoming out stops.

- Rotate in the H direction to increase compression. This make the shock absorption harder.
- Rotate in the S direction to decrease compression. This make the shock absorption softer.

## Rebound Adjustment

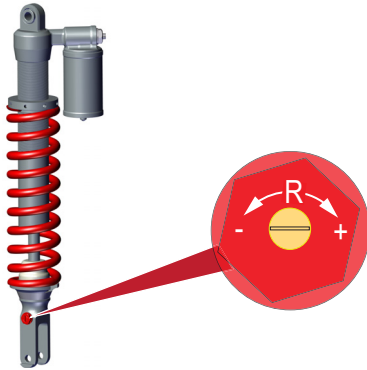

- Rotate in the + direction to increase damping. This slows down the rebound speed.
- Rotate in the - direction to decrease damping. This speeds up the rebound speed.

## Post-Ride Maintenance

1. Clean the surface of the shock immediately after each ride and promptly remove any sediment attached to the surface of the shock tube.

**CAUTION:** When cleaning, do not direct pressurized water or air upwards towards the lip of the dust seal. Doing so can allow contaminants to enter the chamber causing jamming, wear and oil leakage.

2. After cleaning, use a soft cotton cloth and neutral cleaning agent to clean the surface of the fork tube.

**CAUTION:** Do not use solvents that are easily soluble or corrosive to avoid damage to the dust seal.

3. Apply a thin layer of multi-purpose grease on the surface of the suspension rod after cleaning to keep the shock lubricated.

## Wheels And Tires

Inspect both wheels for the following:

- Bent, loose, or missing spokes.
- Bent or cracked rims.
- Impact marks on the rims.
- Check spoke torque:  $29 \pm 7$  lb-in. ( $3.25 \pm 0.75$  Nm)
- If a spoke is broken replace the adjacent spokes in addition to the broken spoke.

Inspect both tires for the following:

- Cuts, cracks, splits, or missing tread lugs in the tread or sidewall area.
- Bumps or bulges within the tire body.
- Uneven tire tread wear. Wear on one side of the tire tread or flat spots in the tire tread indicate a problem with the tire or motorcycle.
- Exposed tire thread or cords.
- Check for excessive tread wear: see Tread Wear Indicators (TWI) on the tires.

If either of the wheels or tires are found to have any of the above conditions, replace the wheel and tire immediately.

## Tire Inflation

**WARNING!** Under-inflation is a common cause of tire failure and may result in severe tire cracking, tread separation, “blowout,” or unexpected loss of motorcycle control, causing serious injury or death.

Tire pressure should be checked and adjusted to the proper inflation levels before each ride. Tire pressure should be checked using an accurate gauge when the tires are cold. This means that the tires have not been ridden on for at least 3 hours. Always replace the valve stem cap when finished adjusting tire pressures.

FRONT	REAR
32 psi (225 kPa)	32 psi (225 kPa)

*NOTE: It is recommended to lower the tire pressure when using off-road tires on forest roads.*

## Drive Chain

### Cleaning The Drive Chain

**WARNING!** Always wear safety glasses when cleaning the chain to prevent eye injuries.

**WARNING!** Never place your hand or any other body part between the chain and sprockets. Work with the chain only in the middle between the two sprockets; failure to do so could result in serious injury.

**WARNING!** Do not allow any of the drive chain cleaner to get on the brake rotors or brake pads. If the brake rotors or brake pads are contaminated with cleaner, it will impair the motorcycle's ability to stop. This could result in serious injury or death.

**WARNING!** Never have the motor spinning the wheel during cleaning. Turn the wheel only by hand. Failure to do so could result in serious injury or death.

Follow the manufacturer's instructions for the chain cleaner you are using; below are the general guideline.

1. Remove the key from the key switch.
2. Set the motorcycle on a stand or lift so the rear wheel is free to spin. While turning the wheel by hand, spray the inside of the entire chain with kerosene and let it sit for a few minutes.
3. Using a brush, fill the bristles with spray from the chain cleaner. Begin gently scrubbing the chain on the top of your swingarm using the brush.

**CAUTION:** If soaking the chain, do not soak in kerosene for more than 10 minutes.

4. Do this for the entire length of the chain. Now do the same thing for the inside/bottom of the chain.
5. Using the brush, clean both sides of the rear sprocket. Let this soak for 5 minutes.
6. Using a water hose, rinse the entire chain. Then, using a clean rag, wipe any residual moisture from the chain.

### Lubricating The Drive Chain

Lubricate the chain every 300 mi (500 km) of motorcycle travel. Lubricate the chain regardless of mileage after riding in rainy or dirty conditions.

**WARNING!** Wear safety glasses when lubricating the chain to prevent eye injuries.

**WARNING!** Never have the motor spinning the wheel. Turn the wheel only by hand. Failure to do so could result in serious personal injury.

**WARNING!** Never place your hand between the chain and sprockets. Work with the chain only in the middle between the two sprockets. Failure to do so could result in serious personal injury.

**WARNING!** Do not allow any of the lubricant to get on the brake rotors or brake pads. If the brake rotors or brake pads are

contaminated with lubricant, it will impair the motorcycle's ability to stop. This could result in serious personal injury.

Use ISO grade 32 or 46 engine oil to lubricate the drive chain.

To lubricate the drive chain:

1. Clean the chain as specified. See ["Cleaning The Drive Chain"](#), on page 6.17.
2. Rotate the wheel backwards slowly and spray the inside of the chain on the inside of the links.
3. Rotate the wheel backwards slowly and spray the outside of the chain on the outside of the links.
4. Let the motorcycle stand for 30 minutes to allow the lubricant to penetrate the link rollers.

## Inspecting the Drive Chain

When scratches, rust, wear, tight links in the chain, detachment of sealing rings, or abnormal noises during operation occur on the chain and gears, it indicates that the chain is damaged and has reached its usage limit. Replace the chain with a new one and simultaneously replace both the front and rear sprockets.

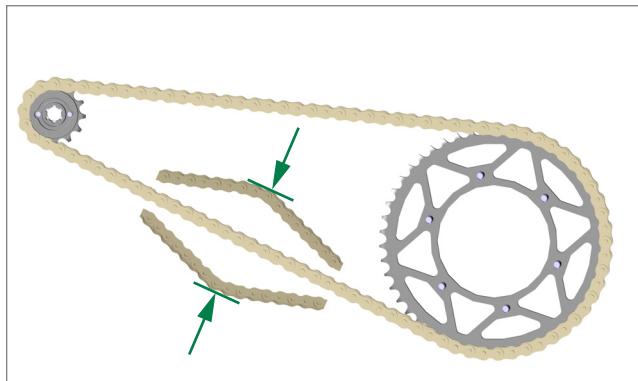

1. Check the cleanliness of the chain and sprocket.
2. Check the wear of the chain and sprocket, as well as the tightness and lubrication level of the chain.
3. Chain sag standard: the upper and lower swings of the chain are between 10 - 15 mm.

### Adjusting the Drive Chain

**WARNING!** If the chain is not properly adjusted, it can be thrown from the sprockets or break. Ensure the chain is properly adjusted to ensure optimal safety.

1. Remove key from the key switch.

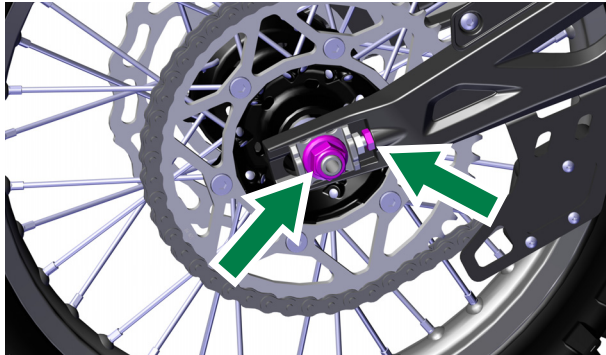

2. Remove the cap and loosen the rear wheel axle nut. Adjust the left and right adjusting bolts to adjust the tension of the chain. When adjusting, keep the left and right chain adjusters in the same position as the mark on the swingarm.

*NOTE: The open end of the clamping spring of the chain joint shall be opposite to the movement direction of the chain.*

3. Once properly adjusted, tighten the axle nut to  $55 \pm 4$  lb·ft ( $75 \pm 5$  Nm).
4. Test ride the motorcycle.
5. Recheck the chain for proper adjustment after the test ride and readjust, if necessary.

## Gear Oil Replace

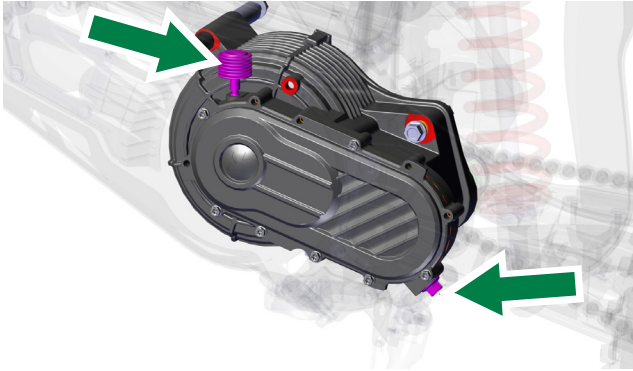

1. Remove the drain plug and drain the gear oil (approx. 6.0 fl oz. (180 ml)).
2. Install the drain plug and remove the breather from the top of the housing.
3. Fill the housing with 6.0 fl oz. (180 ml) of GL-5 85w-90 gear oil and install the breather.

## Kickstand Inspection



1. Ensure the kickstand works properly and does not make any abnormal noises.
2. Check the spring for damage or loss of elasticity.
3. Clean the shaft and lubricate the shaft bolts with multi-purpose grease.

## Steering - Check/Adjustment

1. Install a jackstand under the skid plate to lift the front wheel off the ground.
2. Check the steering from side to side. If the steering column has any play or tightness, adjust the steering column adjusting nut. See [“Component Fasteners”, on page 6.4.](#)
3. Check the handlebar hardware for proper torque.

## Headlight Adjustment

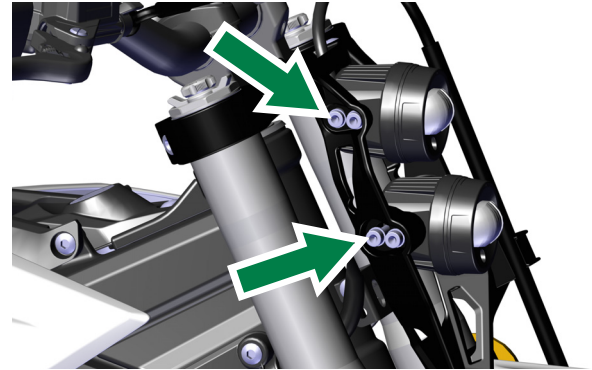

Check the projection height of the headlights before driving. Both lights can be adjusted vertically.

1. Loosen the locking bolts and rotate the light upwards or downwards to adjust the height.
2. Tighten the bolts to lock the position.

## Seat Removal

### Removing the seat

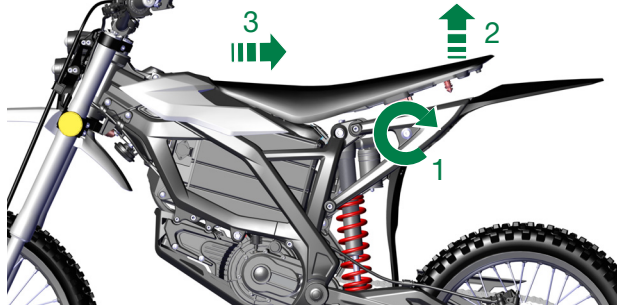

1. Turn off the motorcycle and remove the key. Use the key to unlock the seat by rotating counter-clockwise.
2. Pull up the rear of the seat.
3. Pull the seat to the rear to disconnect from the front post.

## Installing the seat

1. Slide the seat into position until the front of the seat locks onto the seat post.
2. Rotate the seat lock to lock the seat into position. Ensure the seat is securely locked in place before riding.

## Cleaning

**CAUTION:** After the motorcycle is riding, it is recommended that the motor, brake and other high-temperature components should be cleaned after cooling.

1. It is recommended to clean the motorcycle thoroughly with a garden hose.
2. After cleaning, dry the motorcycle with a clean cotton cloth or a clean towel.
3. After drying the vehicle, lubricate the moving parts of the vehicle.
4. Apply a layer of wax on the surface of the plastic appearance parts.

## Precautions

1. Do not use high-pressure water to wash the motorcycle. Pressurized water can damage internal electronic components and circuits.
2. Do not submerge the battery and battery box in water or detergent. Only wash while fully connected in the motorcycle or gently wipe clean with a damp towel carefully avoiding the electrical connectors.
3. Avoid spraying lubricating oil on the brakes or tires during lubrication. Oil-contaminated brake discs and brake pads will greatly reduce braking performance.

4. Do not use products containing strong detergents or chemical solvents for cleaning. Doing so can damage metal, painted and plastic surfaces on the motorcycle.
5. Do not wax the tires and brakes.
6. Water will reduce the braking performance. After cleaning, please ride at low speeds and operate the brakes intermittently to help the brakes dry.

## Storage

1. If parked for more than 30 days, it is recommended to thoroughly clean the motorcycle and keep the battery power at about 40% to 60%, then turn off the key switch.
2. Store and maintain the battery as outlined in [“Battery Guidelines”, on page 5.1](#). When you are ready to use the motorcycle again, fully charge the battery to ensure that the battery is restored to its optimal condition.
3. Do not store the motorcycle in an overheated or humid area to avoid shortening the lifespan of the battery and electrical system.
4. Adjust tire pressure to the specified value, then use jack stands to raise the tires so that the tires do not contact the ground.
5. Store in a ventilated, dry, clean, rain-proof and sun-proof environment, away from flammable, chemical corrosive and other harmful substances.

**CAUTION:** Battery damage caused by improper storage, use and maintenance of the battery is not covered by the warranty.

A series of horizontal dashed lines for writing notes.

## Powertrain Overheating Logic

In certain operating conditions such as during prolonged high power demand, the powertrain temperature can rise over the recommended threshold of 167° F (75 °C). If this occurs, the temperature indicator and the malfunction indicator may illuminate, simultaneously.

If this occurs, fault codes P111 (Controller over temperature 1) and P124 (Motor over temperature 1) will be shown on the dash.

*Note: This behavior does not indicate a malfunction. It is a normal system response designed to provide early notification to the driver of thermal stress in the drive system.*

## Temperature-Dependent Power Management

To protect components from excessive heat, the system automatically reduces power output in stages:

- Initial stage of power reduction to stabilize system temperature - from 239° F (115° C) motor temperature or 221° F (105° C) controller temperature
- Further reduction of drive power to prevent critical overheating - from 248° F (120 °C)

Top speed will be reduced during this time. Once the temperature is within normal range, top speed will return to normal.

## Fault Codes

If a diagnostic code has been recorded, it can be retrieved from dash panel. To retrieve the code, see [“Dash - Menu Interface”, on page 3.16](#) and [“Faults”, on page 3.20](#).

Refer to the table starting on the next page to identify the error associated with the Error Code number.

<b>CODE</b>	<b>DESCRIPTION</b>	<b>ACTION</b>
b103	Cell differential pressure fault 1	Contact your local Zero dealer.
b110	Discharge monomer undervoltage fault 1	Charge the battery.
b114	BMS charging overcurrent fault 1	Reduce charging current.
b119	BMS discharge over temperature fault 1	Motorcycle limit level 1 power usage.
b120	BMS charging over temperature fault 1	Limit charging current.
b121	BMS discharge under temperature fault 1	Motorcycle limit level 1 power usage.
b122	BMS charging under temperature fault 1	Reduce charging current.
b130	BMS discharge overcurrent fault 1	Reduce output current.
b131	Battery insulation fault 1	Contact your local Zero dealer.
b140	Charging unit battery undervoltage fault level 1	Charge the battery.
b141	Uneven temperature fault 1	Contact your local Zero dealer.
b203	Cell differential pressure fault 2	Contact your local Zero dealer.
b210	Discharge monomer undervoltage fault 2	Charge the battery.
b214	BMS charging overcurrent fault 2	Reduce charging current.
b219	BMS discharge over temperature fault 2	Motorcycle limit level 2 power usage.
b220	BMS charging over temperature fault 2	Limit charging current.
b221	BMS discharge under temperature fault 2	Motorcycle limit level 2 power usage.
b222	BMS charging under temperature fault 2	Reduce charging current.
b230	BMS discharge overcurrent fault 2	Reduce output current.
b231	Battery insulation fault 2	Contact your local Zero dealer.
b240	Charging unit battery undervoltage fault level 2	Charge the battery.

<b>CODE</b>	<b>DESCRIPTION</b>	<b>ACTION</b>
b241	Uneven temperature fault 2	Contact your local Zero dealer.
b302	Cell failure	Contact your local Zero dealer.
b303	Cell differential pressure fault 3	Contact your local Zero dealer.
b307	BMS internal MOS failure or relay failure	Contact your local Zero dealer.
b309	Total discharge voltage overvoltage fault	Charge the battery.
b310	Discharge monomer undervoltage fault 3	Charge the battery.
b314	BMS charging overcurrent fault 3	Replace the charger.
b319	MBS discharge over temperature fault 3	Use after the battery temperature decreases.
b320	BMS charging over temperature fault 3	Charge the battery after the temperature decreases.
b321	BMS discharge under temperature fault 3	Use after the battery temperature decreases.
b322	BMS charging under temperature fault 3	Charge the battery after the temperature rises.
b330	BMS discharge overcurrent fault 3	Contact your local Zero dealer.
b331	Battery insulation fault 3	Contact your local Zero dealer.
b332	Battery short circuit failure	Contact your local Zero dealer.
b333	BMS internal communication failure	Contact your local Zero dealer.
b340	Charging monomer battery undervoltage fault level 3	Charge the battery.
b341	Uneven temperature fault 3	Contact your local Zero dealer.
b342	Total charging voltage overvoltage fault	Check the input voltage.
b343	Total discharge voltage undervoltage fault	Check the battery.
b344	Total charging voltage undervoltage fault	Check the input voltage.
b345	Discharge monomer overvoltage fault	Check the battery.

<b>CODE</b>	<b>DESCRIPTION</b>	<b>ACTION</b>
b348	Communication failure	Contact your local Zero dealer.
C101	Charger fault 1	Contact your local Zero dealer.
C106	Temperature fault 1	Reduce charging current.
C107	Input overvoltage protection 1	Check input voltage.
C108	Input undervoltage protection 1	Check input voltage.
C109	Output overcurrent protection 1	Power the motorcycle on and off to reset.
C110	Output overvoltage protection 1	Power the motorcycle on and off to reset.
C111	Output undervoltage protection 1	Power the motorcycle on and off to reset.
C201	Charger fault 2	Contact your local Zero dealer.
C206	Temperature fault 2	Reduce charging current.
C207	Input overvoltage protection 2	Check input voltage.
C208	Input undervoltage protection 2	Check input voltage.
C209	Output overcurrent protection 2	Power the motorcycle on and off to reset.
C210	Output overvoltage protection 2	Power the motorcycle on and off to reset.
C211	Output undervoltage protection 2	Power the motorcycle on and off to reset.
C301	Charger fault 3	Contact your local Zero dealer.
C302	Hardware fault 3	Contact your local Zero dealer.
C303	Communication fault 3	Contact your local Zero dealer.
C304	Short circuit protection 3	Contact your local Zero dealer.
C305	Open circuit protection 3	Contact your local Zero dealer.
C306	Temperature fault 3	Charge after the temperature drops.

<b>CODE</b>	<b>DESCRIPTION</b>	<b>ACTION</b>
C307	Input overvoltage protection 3	Check input voltage.
C308	Input undervoltage protection 3	Check input voltage.
C309	Output overcurrent protection 3	Contact your local Zero dealer.
C310	Output overvoltage protection 3	Contact your local Zero dealer.
C311	Output undervoltage protection 3	Contact your local Zero dealer.
P111	Controller over temperature fault 1	Motorcycle limit level 1 power usage
P112	Electronic TCS malfunction	Contact your local Zero dealer.
P123	Motor controller system fault level 1	Check the controller power cord for looseness.
P124	Motor over temperature fault 1	Motorcycle limit level 1 power usage
P126	Battery imbalance warning prompt level 1	Contact your local Zero dealer.
P211	Controller over temperature fault 2	Motorcycle limit level 2 power usage
P223	Motor controller system fault level 2	Check the controller power cord for looseness.
P224	Motor over temperature fault 2	Motorcycle limit level 2 power usage
P225	Motor temperature sensor failure	Contact your local Zero dealer.
P226	Battery imbalance warning prompt level 2	Contact your local Zero dealer.
P301	Controller overvoltage failure	1. Replace the battery. 2. Replace the controller.
P302	Controller undervoltage failure	Charge the battery.
P303	Controller overcurrent protection failure	Power the motorcycle on and off to reset.
P304	Motor locked failure	Power the motorcycle on and off to reset.
P305	Motor position sensor failure	Contact your local Zero dealer.
P307	Controller phase loss failure	Contact your local Zero dealer.

<b>CODE</b>	<b>DESCRIPTION</b>	<b>ACTION</b>
P309	Braking state	Check the brake switch.
P310	Motor controller self-test failure	Contact your local Zero dealer.
P311	Controller over temperature fault 3	Allow the controller to cool.
P314	Throttle failure	Check if the handle is damaged and if the wiring harness plug is loose
P320	Brake failure	Contact your local Zero dealer.
P321	Communication failure	Contact your local Zero dealer.
P322	Precharge fault	Contact your local Zero dealer.
P323	Motor controller system fault level 3	Contact your local Zero dealer.
P324	Motor over temperature fault 3	Allow the motor to cool.

## General Troubleshooting

SYMPTOM	POTENTIAL CAUSE	POTENTIAL SOLUTION
No power with the key on.	Battery connector not fully inserted	Check and properly insert the battery connector.
	Battery low power protection	Charge the battery.
	Battery in low or high temperature protection	Wait for battery temperature to return to normal.
	Main fuse blown	Check the circuit and replace the fuse.
	Poor contact at key switch connector	Firmly insert the connector or replace the key switch.
	DC converter damaged or malfunction	Replace the DC converter.
	Battery malfunction	Replace the battery at a Zero Dealer.
Charger not charging	Battery temperature too low or too high	Charge the battery after the temperature returns to normal.
	Poor contact of charger connector	Re-insert and secure the charger connector.
	Charger malfunction	Replace the charger at a Zero Dealer.
	Battery malfunction	Replace the battery at a Zero Dealer.
Power mode ineffective or reduced power	Low battery charge	Charge the battery.
	Battery temperature too low or too high	Wait for the battery temperature to return to normal.
	Excessively high temperature of motor or controller	Wait until the temperature returns to normal.
	Damaged power mode switch	Replace the switch.
Power supply normal, battery gauge not displaying	Loose connection at battery gauge	Replace the battery at a Zero Dealer.
	Damaged battery gauge	Replace the battery at a Zero Dealer.

SYMPTOM	POTENTIAL CAUSE	POTENTIAL SOLUTION
Power supply normal, motor not working after power-on	Kickstand switch protection on	Retract the kickstand.
	Brake power-off switch protection	Check the brake switches.
	Motorcycle tip-over switch active	After standing the motorcycle, turn the key off and then back on to reset the switch.
	Throttle not returned to neutral position	Check operation and replace if defective.
	Low battery power protection	Charge the battery.
	Motor overheating protection	Wait for the motor to cool down before use.
	Controller overheating protection	Wait for the controller to cool down before use.
	Damaged kickstand switch	Check kickstand switch connections; replace the kickstand switch.
	Damaged tip-over sensor	Check sensor connections; replace the tip-over sensor.
	Poor contact or damaged throttle	Check throttle connections; replace the throttle.
	Poor contact of controller connector	Inspect and secure the controller connector.
	Poor contact of motor sensor connector	Inspect and secure the motor sensor connector.
Controller malfunction or motor sensor malfunction	Replace the motor at a Zero Dealer.	

## Zero XE Technical Specifications

<b>MOTOR</b>	
Type	Mid-mounted
Estimated Top Speed (max)	53 mph (85 km/h)
Continuous Rated Power	6 kW
Peak Motor Torque	43 lb-ft (58 Nm)
Maximum Torque at Rear Wheel	468 lb-ft (635 Nm)
<b>BATTERY</b>	
Type	Lithium 74V / 58 Ah
Battery Energy	4.3 kWh
Charge Time (standard)	Approximately 5.5 hours
Input	Standard 110 V AC or 220 V AC
Charging Power	800 W, off-board
<b>RANGE</b>	
@31 mph (50 km/h)	65 mi (100 km)
<b>DRIVETRAIN</b>	
Transmission	Variable gear reduction
<b>BRAKES/WHEELS/TIRES</b>	
Front Brakes	240 mm front rotor, dual piston
Rear Brakes	220 mm rear rotor, dual piston

Front Tire	70/100-21M/C or 2.50-19
Rear Tire	90/90-18M/C
Front Wheel	Steel wire wheel: 1.85 x 21 in
Rear Wheels	Steel wire wheel: 2.15 x 18 in.
<b>DIMENSIONS</b>	
Motorcycle Length	81.5 in. (2070 mm)
Motorcycle Width	33.5 in. (850 mm)
Motorcycle Height	47 in. (1195 mm)
Wheelbase	53 in. (1355 mm)
Ground Clearance	12 in. (310 mm)
<b>WEIGHT</b>	
Curb Weight	223 lb (101 kg)
Maximum Payload (Rider + Added Weight)	240 lb (109 kg)
Gross Vehicle Weight (Curb weight + Payload)	463 lb (210 kg)

*Note: Actual cruising range will differ based on factors such as driving habits, road conditions, vehicle load, climatic conditions and tire pressure.*



## Who Is The Warrantor?

Zero Motorcycles Inc. (“Zero”).

## Who Does This Limited Warranty Cover?

This Limited Warranty applies to all original owners and any subsequent owners of the covered 2026 Zero XE motorcycles (“2026 Zero Motorcycles”). It is provided at no additional cost during the applicable warranty coverage period.

Zero requires its authorized dealers to submit warranty registration information on-line or a warranty registration card via mail at the time of purchase to ensure timely service. When a covered 2026 Zero Motorcycle is sold to a subsequent owner, the original owner should submit a warranty transfer request either electronically or in writing. This must be performed to allow Zero the ability to contact the new owner in the unlikely event of a safety related issue. See [“How Do I Transfer Ownership And The Limited Warranty”](#), on page 9.7.

## What Does This Limited Warranty Cover?

Zero warrants that all factory manufactured 2026 Zero Motorcycles are free from defects in material and workmanship during the period of this Limited Warranty.

This Limited Warranty covers parts, including the motor, motor controller, frame, swing arm, fork, rear shock, brake assemblies, wheels and electrical sub-assemblies, and approved Zero accessories installed at the time of purchase by an authorized Zero dealer.

This Limited Warranty also covers the batteries installed on 2026 Zero XE motorcycles.

This Limited Warranty covers all components of the batteries including the integrated battery management system, internal wiring, and internal structures.

### What Is The Coverage Period Of This Limited Warranty?

The duration of this Limited Warranty for 2026 Zero Motorcycles, not including the batteries, is a period of one (1) year from the original “in-service date”.

*The “in-service date” is the earlier of either (a) the date that the authorized dealer performs a pre-delivery inspection (“PDI”) and delivers the motorcycle to the customer; in the event these events occur on different dates, the later date shall be the “in-service date” or (b) the date one (1) year from the date that Zero ships the motorcycle to the authorized dealer.*

The duration of this Limited Warranty for the batteries (not including the battery outer case) is one (1) year from the “in-service date”.

### What Is Not Covered By This Limited Warranty?

Due to the battery chemistry, there is a normal, expected reduction in range/capacity that batteries can yield over time and usage. Depending on use and storage conditions, batteries will degrade during the duration of this Limited Warranty period. Zero will only repair or replace pursuant to this Limited Warranty a battery that exhibits a nominal storage capacity reduction of greater than 20% of the published nominal capacity, as measured by an authorized Zero dealer.

Further, this Limited Warranty only covers 2026 Zero Motorcycles or batteries that are operated according to “proper use” and “under normal operating conditions.” For purposes of this exclusion, the following definitions apply:

- “Normal operating conditions” require routine care and maintenance of the 2026 Zero Motorcycle and batteries as described in this Owner’s Manual.
- “Normal operating conditions” does not include use of the 2026 Zero Motorcycle in for-profit commercial or business activities, such as use as a rental vehicle.
- “Proper use” means only the use of a motorcycle in the manner intended for a rider and passenger on a 2026 Zero Motorcycle with proper safety equipment as described in this Owner’s Manual, in accordance with local regulations.
- “Proper use” also means never storing and/or leaving the battery at a state of charge below 30% for more than 30 days.

In addition, this Limited Warranty does not cover:

- The cost of parts and labor involved in any routine care and maintenance and/or the replacement of parts due to normal wear and tear, use, or deterioration, including but not limited to: tires, brake pads and rotors, belt drive, fork seals, grips, foot pegs, and the seat;
- The tires installed on the 2026 Zero Motorcycle. The original equipment tires are warranted separately by the tire manufacturer;
- The replacement of fluids, unless their replacement is a necessary part of warranty service on a covered component;
- Wheel and spoke damage resulting from off road use;
- Any cosmetic concerns that arise as a result of environmental conditions, owner abuse, misuse, lack of routine care and maintenance, and/or improper use;
- Parts or components damaged by use or operation under abnormal circumstances or contrary to the requirements described in the Owner's Manual including a failure to have the motorcycles firmware updated during the regular service intervals or in a timely basis following a notification that a new update is available.
- 2026 Zero Motorcycles and batteries used for racing or other competitive events;
- 2026 Zero Motorcycles and batteries misused or improperly operated;
- Damage, malfunctions, or performance problems caused by modifications or alterations to 2026 Zero Motorcycles and/or batteries - including modifications or alterations performed by an authorized Zero dealer - that cause the 2026 Zero Motorcycle or battery to fail;
- Damage, malfunctions, or performance problems caused by aftermarket accessories installed on a 2026 Zero Motorcycle or battery after the "in service date," or caused by aftermarket accessories installed by someone other than an authorized Zero dealer;
- Damage, malfunctions, or performance problems caused by the improper repair of the motorcycle, installation of any parts or accessories not sold or approved by Zero, the installation and use of any parties or accessories that alter the motorcycle's specifications from those set by Zero, or the use of new or used parts not approved by Zero;
- Damage, malfunctions, or performance problems caused by the installation or use of any charger not sold or approved by Zero;
- Damage, malfunctions, or performance problems caused by fire, collision, accident, or improper storage;
- Damage, malfunctions, or performance problems caused by continued operation of the motorcycle after a warning light, gauge reading, or other warning indicates a mechanical or operational problem;

- 2026 Zero Motorcycles severely damaged or declared to be a total loss by an insurer, or motorcycles substantially reassembled from or repaired with parts obtained from another used motorcycle;
- Damage, malfunctions, or performance problems caused by the failure to follow recommended maintenance requirements as set forth in this Owner's Manual; and
- Damage, malfunctions, or performance problems caused by airborne industrial pollutants (e.g., acid rain), bird droppings, tree sap, stones, flood water, windstorms, or other similar occurrences.
- Unauthorized modifications to controller firmware or settings

Further, this Limited Warranty does not apply to 2026 Zero Motorcycles or parts and accessories that are not imported or distributed by Zero.

## What Other Limitations Or Disclaimers Apply To This Limited Warranty

The following additional limitations and disclaimers apply to this Limited Warranty:

- **THIS LIMITED WARRANTY IS THE ONLY EXPRESS WARRANTY MADE IN CONNECTION WITH THE SALE OF THIS ZERO MOTORCYCLE MODEL. ANY IMPLIED WARRANTY, INCLUDING ANY WARRANTY OF MERCHANTABILITY OR WARRANTY OF FITNESS FOR A PARTICULAR PURPOSE IS LIMITED IN DURATION TO THE STATED PERIOD OF THIS WRITTEN WARRANTY.**

Some States do not allow limitations on how long an implied warranty lasts, so the above limitation may not apply to you.

- Zero does not assume – or authorize any person to assume – any other obligation or liability on its behalf.
- **THIS LIMITED WARRANTY DOES NOT COVER ANY INCIDENTAL OR CONSEQUENTIAL DAMAGES, INCLUDING LOSS OF VALUE OF THE MOTORCYCLE, LOST PROFITS OR EARNINGS, OUT-OF-POCKET EXPENSES FOR SUBSTITUTE TRANSPORTATION OR LODGING, EXPENSES ASSOCIATED WITH RETURNING THE COVERED PRODUCT TO AN AUTHORIZED SERVICE FACILITY OR DEALER, TOWING AND/OR ROADSIDE ASSISTANCE EXPENSES, EXPENSES ASSOCIATED WITH RETURNING THE COVERED PRODUCT BACK TO ITS OWNER, MECHANIC'S TRAVEL TIME OR**

**COMMUNICATION CHARGES, LOSS OR DAMAGE TO PERSONAL PROPERTY, LOSS OR TIME, OR INCONVENIENCE.**

Some States do not allow the exclusion or limitation of incidental or consequential damages, so the above limitation or exclusion may not apply to you.

- Zero reserves the right to change or improve the design of any 2026 Zero Motorcycle, battery, or any other Zero parts (collectively, “Zero products”) at any time, without assuming any obligation to modify any Zero products previously manufactured or sold.
- The purchaser acknowledges that there is an inherent risk in the operation of motorcycles. This Limited Warranty does not cover - and Zero cannot assume responsibility for - any injury arising from the unsafe or improper operation of Zero products, or the user’s failure to comply with instructions, care and maintenance requirements, warnings, and safety precautions.
- The original registered owner or subsequent registered transferee as documented on the Zero motorcycle warranty registration form is responsible for conveying the Owner’s Manual and all safety warnings, instructions, and Limited Warranty if the unit is sold, loaned, or otherwise transferred to another person.

**What Are Your Responsibilities As A Customer?**

As the owner of a product covered by this Limited Warranty, it is your responsibility to read and understand the Owner’s Manual, this Limited Warranty, and all product warnings before operating your 2026 Zero Motorcycle. Serious injury or death can result from improper operation or failure to observe warnings and safety instructions on any motorcycle.

Further, it is also your responsibility to:

- Perform all recommended and necessary routine care and maintenance and engage in proper use of your Zero motorcycle and battery as detailed in the Owner’s Manual including obtaining any firmware updates available at each service interval or in a timely basis following a notification that a new update is available.
- Learn and obey all federal, state, and local laws governing the operations of a motorcycle, generally, and an electric motorcycle, specifically.
- At all times when operating a 2026 Zero Motorcycle wear proper safety equipment and clothing, including but not limited to helmet, eye protection, and appropriate boots.
- Convey the Owner’s Manual and all safety warnings, instructions, and Limited Warranty if the unit is sold, loaned, or otherwise transferred to another person.

### **What Will Zero Motorcycles Do Under This Limited Warranty?**

During the duration of this Limited Warranty, an authorized Zero dealer will repair or replace (at Zero's discretion), without charge, any 2026 Zero Motorcycle, battery, or parts that are covered by this Limited Warranty and found by Zero or an authorized Zero dealer to be defective in factory materials or workmanship.

### **How Does This Limited Warranty Relate To State Law?**

This Limited Warranty gives you specific legal rights, and you may also have other rights, which vary from State to State.

#### **Notice Under State Lemon Laws**

Some States have laws, sometimes referred to as "lemon laws," allowing you to get a replacement motorcycle or a refund of the purchase price under certain circumstances. These laws vary from State to State. If your state law allows, Zero requires that you first notify us in writing of any service difficulty or issue that you may have experienced so that we can have a chance to make any needed repairs before you are eligible for remedies provided by these laws. In all other States, Zero asks that you give it written notice of any service difficulty or issue.

Please send your written notification to Zero at the following address:

Zero Motorcycles Inc.  
Attn: Customer Service  
380 El Pueblo Road  
Scotts Valley, CA 95066  
USA

## **How Do You Obtain Service Under This Limited Warranty?**

Warranty services may be obtained by contacting your local Zero Motorcycles dealer. Please refer to the dealer locator on our website ([www.zeromotorcycles.com/locator](http://www.zeromotorcycles.com/locator)) for your nearest location.

## **How Do I Transfer Ownership And The Limited Warranty**

If you sell your 2026 Zero Motorcycle, please visit the Zero website and access the owner resources section to fill out the transfer of ownership and warranty form. This must be performed to allow Zero the ability to contact the new owner in the unlikely event of a safety related issue.

## Customer Assistance

Please have the following available when contacting Zero Motorcycles Inc. as they are essential to effectively and efficiently answer your questions or resolve your concerns.

- Owner's name and address
- Owner's telephone number
- Vehicle identification number (VIN)
- Date of purchase
- Motor serial number (if visible)

Zero Motorcycles Inc. can be contacted as follows:

Zero Motorcycles Inc.  
380 El Pueblo Road  
Scotts Valley, CA 95066  
USA

Phone: **+1 (888) 786-9376**

Monday-Friday 8am to 5pm (Pacific Time)

E-mail: [support@zeromotorcycles.com](mailto:support@zeromotorcycles.com) (24 hours)

For updates and additional information about your motorcycle, visit the owner resources section of the Zero website: [www.zeromotorcycles.com/owner-resources/](http://www.zeromotorcycles.com/owner-resources/)

## Reporting Safety Defects

### United States

If you believe that your vehicle has a defect which could cause a crash or could cause injury or death, you should immediately inform the National Highway Traffic Safety Administration (NHTSA) in addition to notifying Zero Motorcycles Inc.

If NHTSA receives similar complaints, it may open an investigation, and if it finds that a safety defect exists in a group of vehicles, it may order a recall and remedy campaign. However, NHTSA cannot become involved in individual problems between you, your dealer, or Zero Motorcycles Inc.

To contact NHTSA, you may call the Vehicle Safety Hotline toll-free at:

1-888-327-4236 (TTY: 1-800-424-9153); go to <http://www.safercar.gov>; or write to:

Administrator  
National Highway Traffic Safety  
1200 New Jersey Avenue SE  
Washington, DC 20590

You can also obtain other information about motor vehicle safety from:

<http://www.safercar.gov>

**Canada**

If you believe that your vehicle has a defect which could cause a crash or could cause injury or death, you should immediately inform Transport Canada, in addition to notifying Zero Motorcycles Inc.

To contact Transport Canada, call their toll-free number:

+1-800-333-0510

**United Kingdom, Europe, and Global Markets**

If you believe that your vehicle has a defect which could cause a crash or could cause injury or death, you should immediately inform your Zero Motorcycles authorized dealer. If you are unable to resolve the issue with your Zero Motorcycles authorized dealer you can contact Zero Motorcycles Inc. directly on +1-888-786-9376, or through our website at:

<http://www.zeromotorcycles.com>

A series of horizontal dashed lines for writing notes, consisting of 15 rows of evenly spaced dashes.

## Service History

After you have had your Zero motorcycle serviced, please make sure that the appropriate maintenance record has been completed.

Use the space under “Notes” to record issues you want to remind yourself about or mention at the next service.

Initial 60 miles (100 km)	
Odometer reading:	Date:
Notes:	
Performed by:	

Initial 300 miles (500 km)	
Odometer reading:	Date:
Notes:	
Performed by:	

1,250 miles (2000 km)	
Odometer reading:	Date:
Notes:	
Performed by:	

3100 miles (5000 km)	
Odometer reading:	Date:
Notes:	
Performed by:	

6200 miles (10,000 km)	
Odometer reading:	Date:
Notes:	
Performed by:	

A series of horizontal dashed lines for writing notes.

**B**

Battery .....	6.9
Guidelines .....	5.1
Removal, Installation .....	5.4
Bolt Torque Specifications .....	6.4
Brake Fluid .....	6.11
Brakes .....	6.9
Braking .....	4.4
Brightness .....	3.18

**C**

Charging .....	5.2
Cleaning Your Motorcycle .....	6.23
Clock .....	3.15, 3.20
Contact information	
NHTSA .....	9.8
Zero Motorcycles .....	9.8

**D**

Dash	
Buttons .....	3.6
Menu .....	3.16
Overview .....	3.12
Theme .....	3.17
Drive Chain .....	6.17
Adjustment Procedure .....	6.19
Cleaning .....	6.17
Lubricating .....	6.17

**F**

Fault Codes .....	3.20, 7.1
-------------------	-----------

**G**

General Operation .....	4.1
Pre-Ride Inspection .....	4.1
General Safety Precautions .....	2.1

**H**

Headlight Adjustment .....	6.21
----------------------------	------

**I**

Inspection	
Pre-Ride .....	4.1
Instrument Panel .....	3.12

**K**

Kickstand .....	6.20
-----------------	------

**L**

Labels .....	2.4
Language .....	3.19
Log book .....	10.1

**M**

Maintenance Record .....	10.1
Maintenance Schedule .....	6.1
Motor Serial Number .....	1.3

## O

Oil	
Gear oil.....	6.20
Operating Your Motorcycle .....	4.4
Braking.....	4.4
Stopping .....	4.4

## P

Powertrain .....	4.5
Pre-Ride Inspection .....	4.1

## R

Reporting safety defects.....	9.8
Reset .....	3.22
Ride Modes .....	3.11
Ride Settings.....	3.16

## S

Safe Riding Precautions.....	2.2
Seat	
Removal .....	6.22
Serial Number	
Motor .....	1.3
Specifications .....	8.1
Steering Adjustment.....	6.21
Steering Lock .....	4.2
Suspension	
Front .....	6.11

Front Compression .....	6.12
Front Preload.....	6.12
Rear Compression .....	6.14
Rear Preload.....	6.14
Rear Rebound .....	6.15
Rear Shock .....	6.13
Switch	
Key .....	4.2
Left Combination.....	3.4
Right Combination .....	3.5
System Info.....	3.21

## T

Time.....	3.20
Tip-Over Sensor.....	4.3
Tire Inflation .....	6.16
Troubleshooting .....	7.7

## U

Units Setting.....	3.19
--------------------	------

## V

Vehicle Identification Number (VIN)	
Location .....	1.2
Vehicle Nameplate.....	1.2

## W

Warranty	
----------	--

Coverage.....9.1  
Exclusions .....9.2  
Transfer Of Ownership And Warranty .....9.7  
Wheels And Tires .....6.16



# First Responder Information – High Voltage Component Locations

 **WARNING**

 **DO NOT CUT  
COLORED  
ZONES**

 **NEVER** cut high voltage components or cabling. Cutting could result in serious injury or death.

 High voltage cables and components may remain energized for up to 60 seconds after disabling.

 HIGH-VOLTAGE



**ZERO**  
MOTORCYCLES®



ZEROMOTORCYCLES.COM  
8812082-AG